

TABLE OF CONTENTS

G50 SITE COMMUNICATIONS

G5010 SITE COMMUNICATIONS SYSTEMS.....2

RECORD OF REVISIONS (G50)

| Rev | Date | Description | POC | OIC |
|------------|-------------|--|------------------------------|------------------------------|
| 0 | 2/23/2015 | Initial issue as G50 in Ch. 19. Changes to address redundant paths, SME reviews, construction requirements under parking lots and roadways, update refs. | <i>Pete Lowe, NIE-TS</i> | Mel Burnett, <i>ES-FE</i> |

RECORD OF REVISIONS (G4030)

| Rev | Date | Description | POC | OIC |
|------------|-------------|---|---|------------------------------------|
| 0 | 06/28/99 | Rewritten and reformatted to support LIR 220-03-01. Superseded FE Standards, Volume 7, Electrical, Manual Rev 15, 6/26/98. | David W. Powell, <i>PM-2</i> | Dennis McLain, <i>FWO-FE</i> |
| 1 | 11/18/02 | General rev and addition of endnotes. Replaces Subsections 211.2.3 – 211.2.7, 245.8, and 273.4.3 | David W. Powell, <i>FWO-SEM</i> | Kurt A. Beckman, <i>FWO-SEM</i> |
| 2 | 10/27/06 | Admin changes only. Sections 2.0 and 3.0 were deleted, superseded by ESM Ch 9 Sections 5.6-H and 5.5-C. Org and contract reference updates from LANS transition. Became ISD. Master Spec number/title updates. Other admin changes. | David W. Powell, <i>FM&E-DES</i> | Kirk Christensen, <i>CENG</i> |

G50 SITE COMMUNICATIONS

This section governs unclassified (open) communications work outside of buildings. For inside buildings, refer to ESM Chapter 19 Section D60. For secure (classified) work refer to ESM Chapter 18.

G5010 SITE COMMUNICATIONS SYSTEMS

1.1 Definitions¹

- A. **Entrance facility** is an entrance to a building for both public and private network service cables (including antennae) including the entrance point at the building wall and continuing to the entrance telecommunications room or space.
- B. **Loop diversity** is the placing of alternate facilities to temporarily replace the main system in case of failure.
- C. **Manhole (MH):** A vault located in the ground as part of an underground telecommunications duct system and used to facilitate placing, connecting, and maintenance of cables as well as the placing of associated equipment, in which it is expected that a person will enter to perform work.
- D. **Pathway** is the vertical and horizontal route of the telecommunications cable.
- E. **Redundant Path:** An installation of a secondary or alternate path or system so that if one system goes down, the connection between other systems will not be broken.
- F. **Telecommunications room** is an enclosed space for housing telecommunications equipment, cable terminations, and cross-connects. The room is the recognized cross-connect between the backbone cable and horizontal cabling.²

1.2 General Planning and Design Considerations

- A. Provide site telecommunications systems as described in this section and as required to meet the User's programmatic needs. Coordinate requirements with the LANL Telecommunications Group.
- B. Provide NIE-TS liaison with 30%, 60%, 90% and final design and specs for review and approvals.
- C. Meet requirements of the latest adopted editions of (and addenda and amendments to) the following telecommunications standards, the National Electrical Safety Code (NESC), the National Electrical Code (NEC) and this chapter of the LANL Engineering Manual:
 - 1. TIA-569, *Telecommunications Pathways and Spaces*³

¹ Definitions adapted from the BICSI Telecommunications Dictionary to suit conditions at LANL

² Chapter 6, Backbone Distribution Systems, and Chapter 7, "Telecommunications Spaces" in the BICSI *Telecommunications Distribution Methods Manual*, 12th Ed

³ The TIA telecommunications standards provide minimum requirements for wiring, pathways and spaces, grounding, and administration of telecommunications systems in commercial buildings.

2. TIA-607, *Generic Telecommunications Grounding and Bonding*³
 3. TIA-758, *Customer-Owned Outside Plant Telecommunications Infrastructure Standard*³
 4. BICSI Telecommunications Distribution Methods Manual
- D. Use the materials and installation methods described in LANL Master Specifications Sections 27 1000, *Structured Cabling* and 33 7119, *Electrical Underground Ducts and Manholes*.
- E. Refer to ESM Chapter 9-Security for requirements and guidance on building security system service entrances.
- F. Loop Diversity⁴
1. Provide loop diversity for special facilities such as safety/security operations centers, computer centers, and prime telecommunications centers. Levels of loop diversity are described in Table G5010-1.

Table G5010-1: Loop Diversity

| Level of Loop Diversity | Assign Circuits... |
|-------------------------|--|
| Count | Among different binder groups within one cable |
| Sheath or cable | Among different sheaths or cables |
| Route | Along entirely different cable paths to a building |

2. Coordinate with the LANL Telecommunications Group and the facility user to balance costs versus risks in considering the appropriate level of loop diversity. In addition to addressing disasters such as water, fire, lightning, wind, and construction damage, consider the less likely but equally serious possibilities such as earthquakes, nuclear attack, or sabotage.
 3. Provide dual (duplicate) service entrances (two 100-percent diverse routes) as emergency backup for buildings that provide continuous services, including:
 - safety/security operations centers,
 - fire stations,
 - telecommunications centers, and
 - computer centers.

Although the duplicate entrance route may be left vacant, some critical operations may warrant fully installed duplicate facilities for immediate activation in emergencies.
- G. Provide underground pathways where possible. Use aerial entrances only as a last resort and subject to the limitations described in the heading “Aerial Plant” in this section.⁵

1.3 Underground Pathways

A. Sizing Underground Entrance Conduits

⁴ “Loop Diversity” heading in “Backbone Distribution” chapter of the *BICSI Telecommunications Distribution Methods Manual*, 12th Ed.

⁵ “Aerial Entrances” heading in Chapter 20 “Outside Plant” of the *BICSI Telecommunications Distribution Methods Manual*, 12th Edition

1. Install a minimum of two telecommunications⁶ entrance conduits (plus security⁷ service entrance conduits as described by ESM Security, Chapter 9) from the point of connection to the network into the entrance telecommunications room; coordinate design for each project with the LANL Telecommunications Group. *Point of connection to the network will be a maintenance hole (MH) or a telephone pedestal.*
 2. Provide entrance conduits based on the anticipated number and type of telecommunications circuits that will be brought into the building. *In office buildings, this anticipated number is often calculated as one entrance pair per 100 ft² of usable office space.* Coordinate with the LANL Telecommunications Group. Refer to table in D60 for number and size of required conduits.
- B. Route pathways away from sources of electromagnetic interference such as electrical power wiring, radio frequency sources, power transformers, large motors and generators, induction heaters, arc welders, etc.⁸ If entrance pathways must be installed in close proximity (less than 24 inches) and parallel to potential sources of significant electromagnetic interference, use galvanized rigid steel conduit, intermediate metallic conduit (IMC), or similar raceway that will provide effective shielding.
 - C. Maintain 10 ft separation from building foundations to underground telecommunications pathways (except at entry points).⁹
 - D. Where optical fiber cables will be used, place three 1.5-inch innerducts or three separate 3-cell innerducts in each 4-inch conduit designated for this purpose to ensure physical cable protection.¹⁰
 - E. Provide a woven polyester detectable pull tape (1,200-lb test) with stamped footage markings pulled into each service conduit and innerduct and tied off at each end.¹¹
 - F. Seal the building and MH ends of each pathway to prevent rodents, water, or gases from entering the building or MH. Use rubber conduit plugs or duct sealer, depending upon the conditions. Reseal conduits after cable is placed in them.¹²
 - G. Set trench minimum depth to provide 24 inches of cover from the top of the conduit or concrete envelope to final grade.
 - H. Bore drilling under roadways requires 1ea. 4”RMC conduit at a minimum depth of 36” from the top of conduit to bottom of pavement and bar ditch. Extend conduit outward a minimum of 36” beyond pavement or roadway.
 - I. Design ductbanks to slope toward MHs at not less than 4 inches per 100 feet.¹³

⁶ §9.4.2.2 in TIA-569-C

⁷ Argus security system requirement

⁸ §10.3 in TIA-569-C

⁹ Clearance required so maintenance or repairs to pathway can be accomplished without damaging the building.

¹⁰ §5.1.1.2.7 in TIA/EIA-758-A and the “Placing Innerducts” heading in Chapter 9 of the *BICSI “Outside Plant Design Reference Manual” (OSPDRM)*

¹¹ Footage markers facilitate ordering the correct length cable

¹² §5.1.1.2.8 in TIA/EIA-758-A

¹³ §5.1.1.2.6 in TIA/EIA-758-A

J. Avoid bends in underground telecommunications conduits and ducts. Do not include more than two 90-degree bends between pulling points when installing underground pathways. Never exceed a 90-degree bend.¹⁴

K. All conduit bends must be long, sweeping bends with a radius not less than:

1. Six times the internal diameter of conduits 2 inches or smaller, or
2. Ten times the internal diameter of conduits larger than 2 inches.¹⁵

L. Provide concrete encased ductbank construction for underground telecommunications pathways when:

1. The cables are part of the telecommunications main system facility.
2. The conduits serve a critical facility such as:
 - safety/security operations centers,
 - fire stations,
 - telecommunications centers, or
 - computer centers.
3. Minimum conduit depth of 24 inches cannot be attained.
4. Conduits pass under roads, driveways, or parking lots that cannot maintain a 36" depth
5. Bend points might be subject to movement.

Use concrete with a minimum compressive strength of 3,000 lb/in². Place reinforcing bars at joints between concrete pours and at any location subject to extra stress.¹⁶

M. Install a 4/0 AWG bare copper ground cable centered within each ductbank; connect to ground cable in MHs and ground bars in building entrance telecommunications rooms using irreversible compression connectors.

N. Refer to Figure G5010-1 for maximum section lengths between MHs.¹⁷ *Increasing the radius of bends significantly extends the length of duct runs between MHs. When bend radii of less than 10 ft are used, section lengths are reduced drastically.*

¹⁴ §C.5.1.3.1 in TIA-569-C

¹⁵ §C.5.1.3.1.2 in TIA-569-C

¹⁶ §5.1.1.2.2 in TIA/EIA-758-A

¹⁷ Figure C.5-2 in TIA-569-C

Figure G5010-1: Maximum Section Length Between Manholes

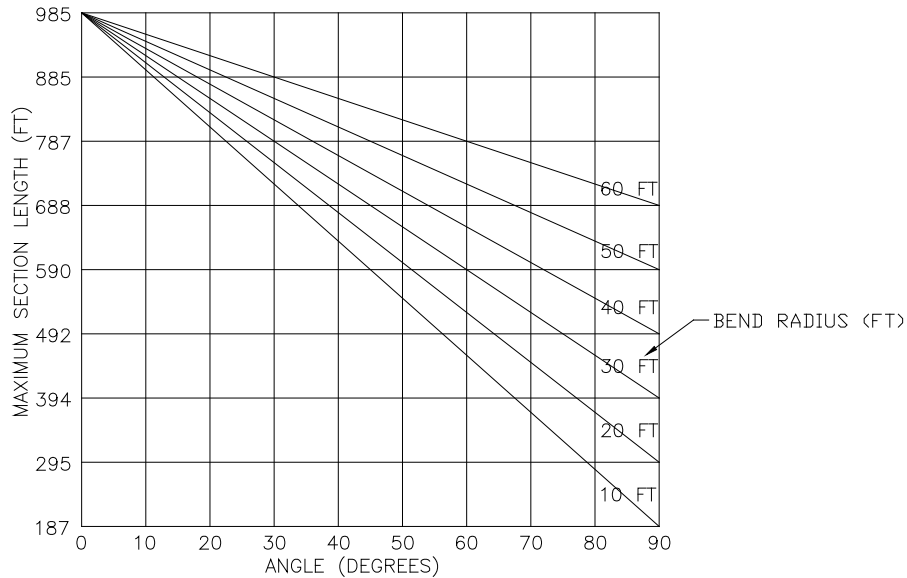

- O. Provide maintenance holes (MH) to pull-in and splice cables in telecommunications underground pathways based on the following criteria:
1. As required so no conduit or duct section length exceeds 600 ft.¹⁸
 2. As required for duct or conduit drainage,¹⁹
 3. As required so duct or conduit sections with bends do not exceed lengths in Figure G5010-1 based on bend radii and total bend angle.¹⁷
 4. As required to provide entrance pathways to facilities.
- P. Provide telecommunications MHs with the following minimum inside dimensions: 12'-0" long, 6'-0" wide, 7'-0" high or 8'-0" long, 6'-0" wide, 7'-0" high. Coordinate MH size requirements with LANL Telecommunications Group. Figure G5010-2 shows a typical telecommunications MH. Figure G5010-3 shows some typical MH configurations; configuration "A" is preferred.
1. Use pre-cast concrete MHs where site conditions and MH design requirements permit. Use cast-in-place concrete MHs where pre-cast MHs are not practical.
 2. Equip telecommunications MHs with a minimum 8-inch-diameter sump, corrosion resistant pulling irons, cable support racks, and fixed ladders. Provide one hot dip galvanized steel pulling iron under each knockout panel, two along each side wall and one under the MH access opening (total of seven).
 3. Provide MH covers and ladders as follows:
 - Up to 12 ft long MH, one cover and fixed ladder.
 - Between 12 ft and 20 ft long, two covers and fixed ladders.
 - Over 20 ft long, three covers and fixed ladders.

¹⁸ §5.1.1.2.3 in TIA/EIA-758-A

¹⁹ §5.1.1.2.6 in TIA/EIA-758-A

4. Mark all MHs or pull boxes for easy identification. Stamp the MH/pull box structure number on the north side of each ring or frame and on each lid or cover.

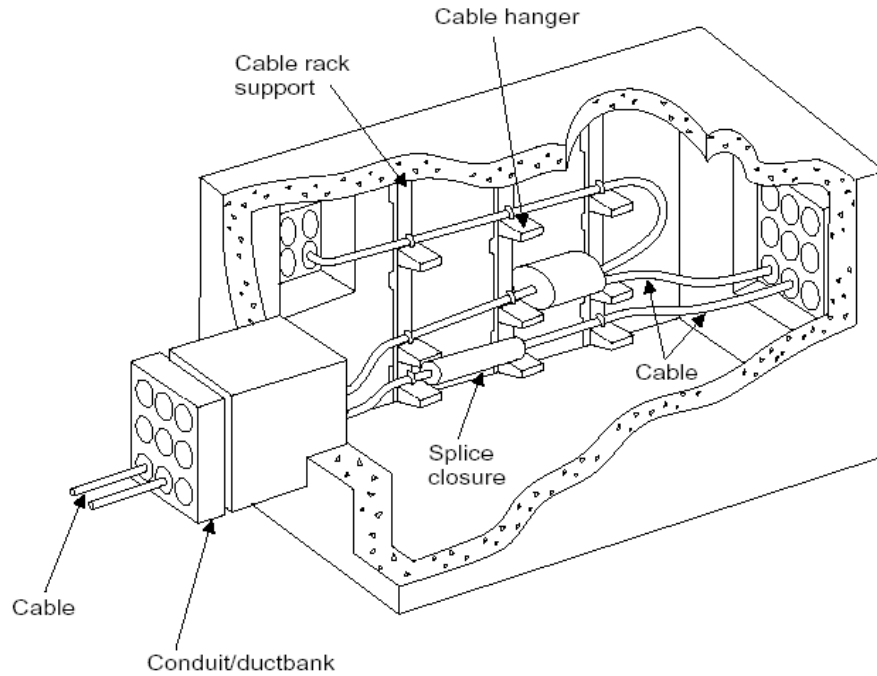

Figure G5010-2: Typical Telecommunications Manhole

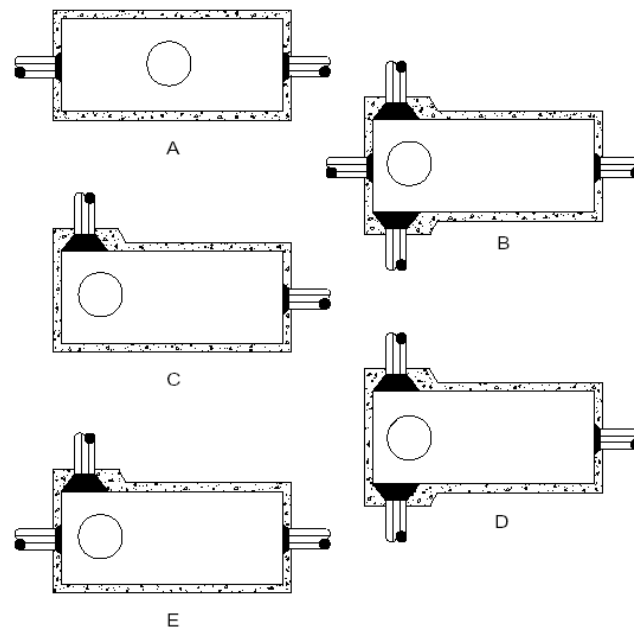

Figure G5010-3: Basic Telecommunications Manhole Configurations

- Q. Locate MHs with consideration to ground topography, soil conditions, surrounding structures, personnel access, and placing and splicing cables. Place MHs to be close to street intersections within the right of way, but outside the traveled portion of the street. Do not place MHs within 50 ft of the curb radius or right of way line of the intersecting road. Where MHs must be placed in the traveled portion of the road, locate MH cover 5 ft from the curb.²⁰
- R. Use handholes not exceeding 4 ft in length by 2.5 ft in width by 3 ft in depth as an aid to cable pulling in entrance duct runs of not more than three 4-inch conduits, subject to the following limitations:²¹
1. Do not use a handhole in place of a MH in a main system facility.
 2. Do not use a handhole for splicing cables; use a MH for splicing.
 3. Do not use a handhole for angle or offset pulls; conduits entering a handhole must be aligned on opposite sides of the handhole at the same elevation. Use a MH for angle or offset pulls.
- S. Where possible place conduit entry points at opposite ends of a MH or pull box, instead of through the sidewalls.²² Coordinate locations of knockout panels in MHs with LANL Telecommunications Group.
- T. Refer to LANL Master Specification Section 33 7119- *Electrical Underground Ducts and Manholes* for materials and installation methods.

1.4 Aerial Plant

- A. Planning and Designing Considerations²³
1. Consider aerial design only as a last resort when underground an underground pathway design is prohibitively expensive or is not feasible due to temporary area construction.
 2. Select permanent locations for pole lines considering:
 - Future road widening or realignment.
 - Expansion of other utilities.
 - Special problems such as road and power line crossings.
 - Safety and convenience of workers and the public.
 3. Obtain necessary permits and easements for building and maintaining pole lines on and over public right-of-way.
 4. Coordinate with other utilities with respect to:
 - Possible joint use.
 - Minimizing inductive interference.
 5. Design pole line for ultimate needs, considering:

²⁰ §5.2.1.2 and Figure 8 in TIA/EIA-758

²¹ §C.6.2 in TIA-569-C

²² While placing the conduit entry points at opposite ends may require an additional conduit sweep, it provides the following benefits: (1) allows neater cable formation in the MH/pull box; (2) maximizes the available working space at the center of the MH/pull box; (3) permits splaying (offset closer to the side walls) the entry points in certain situations.

²³ “Aerial Entrances” heading in Chapter 20 “Outside Plant” of the *BICSI Telecommunications Distribution Methods Manual*, 12th Ed.

- Pole line classification.
 - Storm loading.
 - Clearance requirements.
6. Use the most economical span-length within the constraints imposed by the design guidelines while allowing for maximum growth of future cable feeders.
 7. When adding cable to an existing line or when establishing a joint-use line, ensure that the pole strength and clearances are adequate.
- B. Design aerial plant in accordance with the National Electrical Safety Code.
- C. Aerial Entrances
1. Limit aerial entrances to small buildings requiring:
 - One hundred cable pairs or less.
 - No other communications entrances.
 2. Aerial entrances tend to be undesirable because of their:
 - Lack of mechanical protection for the facility.
 - Effect on the aesthetics of the building.
 - Clearance requirements.
 - Storm-loading requirements.
 3. When aerial entrances are used, the span from the last pole to the building must not exceed 100 ft. Use slack-span construction (i.e., no guying at either end).²⁴
- D. Joint use of Structures
1. Consider joint use of structures when aerial construction is planned.²⁵
 2. Verify that construction grade is adequate for the total weight of conductors, that there is adequate space on existing structures, and that there is low probability of electromagnetic interference between systems.²⁶ Refer to the “Joint Use” heading in ESM Chapter 7 Section G4010 for additional guidance.
 3. Arrange systems on poles in the following descending order:²⁷
 - Medium-voltage power
 - Low-voltage power
 - Telecommunications
 - Fire alarm
 - Security
 4. Provide clearances to ground, roadways, structures, and between system conductors and cables as required by Part 2 of the NESC.

1.5 Telecommunications Cables

Underground and aerial telecommunications cables shall be furnished, installed, terminated, labelled, and tested in accordance with Section D60 and ESM Chapter 7 Section D5000.

²⁴ To place as little pulling tension as practical on building attachments and support structures

²⁵ NESC Rule 222

²⁶ §5.1.1.2.6 in TIA/EIA-758

²⁷ NESC Section 22