

**TABLE OF CONTENTS**

1.0 INTRODUCTION AND APPLICABILITY .....6

2.0 SECTION OVERVIEW .....8

3.0 QUALIFICATION REQUIREMENTS.....9

**A. Pressure System Designers..... 9**

**B. Pressure System Reviewers..... 9**

4.0 PRESSURE SAFETY COMMITTEE .....9

5.0 DEFINITIONS AND ACRONYMS .....9

6.0 GENERAL PROGRAM STATEMENTS .....17

**A. Basic program requirements ..... 17**

7.0 EXCLUDED PRESSURE VESSELS, RELIEF DEVICES, AND SYSTEMS .....19

**A. Pressure Systems..... 19**

**B. Pressure Vessels ..... 20**

**C. Pressure Relief Devices..... 21**

**D. Calculations ..... 21**

8.0 SYSTEM IDENTIFICATION TAG.....22

**A. System Identification and Inventory Method..... 22**

9.0 PRESSURE SYSTEM CERTIFICATION PROCESS .....24

**A. Process Flow Chart..... 24**

**B. General..... 26**

C. Preparing a New or a Modified Pressure System for Certification ..... 27

D. Recertifying an Existing Pressure System for Use ..... 29

E. Tracking of Pressure Systems Annual Recertification Status..... 29

F. Conflict of Interest ..... 29

G. Documenting Non-conformances..... 29

H. Deactivating a pressure system..... 30

10.0 DESIGN AND DOCUMENTATION ..... 31

A. Calculations ..... 31

B. Cryogenic systems..... 31

C. DOT vessels ..... 32

D. Drawings and sketches ..... 32

E. Finite Element Analysis..... 33

F. Fitting and Fastener Assembly ..... 34

G. Flexible Hoses and Tubing ..... 34

H. Fluid Category Determination..... 34

I. Gas Cylinder Pressure Systems ..... 35

J. Hydrogen and Flammable Fluid Pressure Systems ..... 36

K. Labeling and tagging of components..... 37

L. Liquid lock..... 37

M. Oxygen Systems ..... 38

N. Piping and Tubing ..... 38

O. Piping Components..... 40

P. Unlisted, Specialty, or Unique Components ..... 40

Q. Piping Flanged Joint Connection Assembly ..... 41

R. Piping Supports and Flexibility Analysis..... 41

S. Pressure and Vacuum Gauges ..... 42

T. Pressure Relief Requirements..... 42

U. Restraints for flexible hoses, tubing, and relief device discharge tubing. .... 47

V. Pressure Vessel Requirements ..... 49

W. System Interactions ..... 50

X. Vacuum and Externally pressurized components and piping..... 51

Y. Vent Systems ..... 52

Z. Welding Design ..... 52

11.0 PROCUREMENT, FABRICATION, AND ASSEMBLY ..... 53

A. General..... 53

B. Rental Pressure Systems..... 53

C. ASME Code-Stamped Vessels..... 53

D. Non-Code Vessels..... 54

E. Flexible Hoses and Flexible Tubing Procurement ..... 54

F. Tagging and Labeling ..... 54

G. Welding, Brazing and Soldering..... 55

H. Piping and Tubing ..... 55

I. Cleaning..... 56

J. Alignment ..... 56

K. Flanged joint assemblies: ..... 57

L. Threaded Joints..... 57

M. Tubing Joints ..... 57

N. Oxygen and Oxidizing media components cleanliness requirements ..... 58

12.0 INSPECTION, TESTING, AND MAINTENANCE.....60

A. Inspection/Examination..... 60

B. Testing..... 61

C. Fluid Service Categories, Inspection, and Inspection/Testing Intervals. .... 62

D. Corrosion and Remaining Life ..... 67

E. PassPort Database (CMMS) ..... 68

F. DMAPS Database ..... 69

G. Repairs or Alterations (Welding) ..... 69

13.0 DOT, IM, AND UM PORTABLE TANKS .....70

A. Special Instructions for DOT-4L Cylinders ..... 70

B. Inspection Frequencies ..... 70

14.0 MOBILE PRESSURE SYSTEMS AND TRANSPORT TANKS .....72

A. Definitions..... 72

B. Procurement..... 73

C. Pressure Relief Devices..... 73

D. Piping, Valves, and Fittings..... 73

E. Pressure System Documentation Package ..... 73

F. Repairs and Alterations..... 74

G. Tests and Inspections..... 74

15.0 PRESSURE SYSTEM DOCUMENTATION PACKAGE CONTENTS .....75

A. Required documentation table (to be maintained in pressure system documentation package). ..... 75

Record of Revisions

Rev.	Date	Description	POC	OIC
0	3-10-09	Initial issue.	Charles DuPre, ES-DE	Kirk Christensen, CENG-OFF

PLEASE CONTACT THE ESM CHAPTER POC (CPSO)

for upkeep, interpretation, and variance issues

<b>Section I</b>	<b><u><a href="#">Pressure Safety Committee</a></u></b>
------------------	---

The LANL Engineering Standards including this one are available to all at <http://engstandards.lanl.gov>

Additional resources for the implementation of this document are available to all LANL personnel at the following SharePoint site: <http://wespsrv1:19567/sites/ADE/COE/SWREF/Documents/Forms/AllItems.aspx>

CPSO/PSO SharePoint pressure system inventory site (future):  
[http://wespsrv1:19567/sites/ADE/COE/PRES/\\_layouts/viewlsts.aspx](http://wespsrv1:19567/sites/ADE/COE/PRES/_layouts/viewlsts.aspx)

## 1.0 Introduction and Applicability

- A. This Section I, Program Requirements, of Engineering Standards Manual Chapter 17, Pressure Safety contains the requirements for design and management of pressure systems to ensure that pressure systems at LANL are compliant with applicable ASME codes or equivalent as required by [10CFR851](#) Appendix A, Part 4<sup>1</sup>.

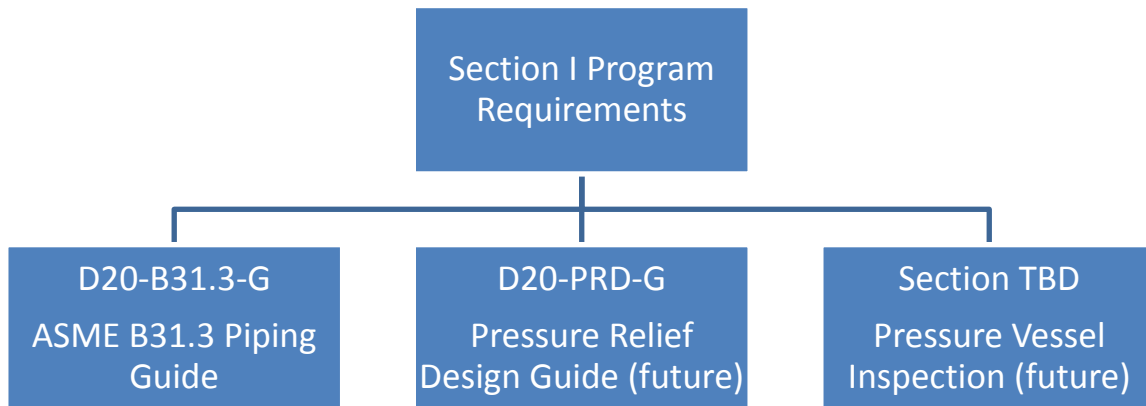

- B. This chapter supersedes the design, review, testing, and pressure program management requirements of LANL [P 101-34](#), Pressure, Vacuum, and Cryogenic Systems.<sup>2</sup> The operational safety requirements and functions in P 101-34 still apply and are not addressed by this chapter.
1. Examples of such safety requirements not covered by this chapter are: personal protective equipment, skin injection, moving of gas cylinders, securing of gas cylinders, cryogen burns, chemical hazards, oxygen deficiency, chemical compatibility, material compatibility, operation and maintenance training requirements, etc.
- C. This Chapter also supersedes Requirements Notice RN0803, *Pressure Safety*, and any conflicting pressure protection design, inspection, and maintenance requirements (e.g., intervals) in ESM Chapter 6 Mechanical Section [D20](#); [O&M Criterion](#) 403, *Boilers*; and Criterion 419, *Inspections and Testing of Pressure Vessels and Pressure Relief Valves*.

<sup>1</sup> 10 CFR 851 Part 4 is reproduced in Appendix A of this Section I.

<sup>2</sup> Formerly LIR 402-1200-01. P 101-34 is to be revised to delete these topics in 2009.

- D. Pressure systems (facility and programmatic) that are subject to a source pressure greater than 15 psig (pounds per square inch gauge) are subject to the requirements of this program and the applicable ASME BPVC and B31 piping codes except as noted.
1. Vacuum systems (regardless of pressure system interface) are subject to the requirements of this document.<sup>3</sup>
  2. Cryogenic systems that are not open to the atmosphere at all times are also subject to the requirements of this document.
- E. Pressure systems with source pressures always less than 15 psig are subject to the inventory and certification process as defined in this document. Excluded are: atmospheric tanks<sup>4</sup>, facility services piping<sup>5</sup>, and other applications listed under Exclusions.
- F. Projects Underway: Projects in design or fabrication stages must also follow this chapter and shall be in full compliance prior to fluid introduction including system pressure testing (not component or pipe section testing).<sup>6</sup>
- G. Throughout this document there are references to specific ASME code paragraphs or sections. For most cases across the Laboratory, the appropriate codes are B31.3<sup>7</sup> and Section VIII of the Boiler and Pressure Vessel Code. However, the most applicable code shall be used per application (e.g., use B31.5 for refrigeration piping vs. B31.11).
1. Where a pressure system specifically falls within the scope of a piping code other than B31.3, (e.g., building water systems that fall within the scope of B31.9) it shall be designed, fabricated, inspected and tested in accordance with the most applicable code, and requirements in this Section I referring to or taken from B31.3 shall be taken to mean the corresponding provisions in the applicable B31 code. Documentation must be maintained to prove compliance with the applicable code.
- H. Documentation, including forms, generated by this program shall be considered records, and shall be managed per LANL P 1020, P 1020-1, and P 1020-2 ([URL](#)).

---

<sup>3</sup> [10 CFR 851](#) Definitions (FR pg 6871) states “Vacuum systems should be considered pressure systems due to their potential for catastrophic failure due to backfill pressurization.”

<sup>4</sup> But must be protected from over/under-pressure by vacuum breaks and/or vents.

<sup>5</sup> Must be designed to B31.9 (or UPC as applicable), but is not inventoried nor required to have a PM program due to acceptance of this risk by industry (commercial practice).

<sup>6</sup> Although ESM Ch 1 Section Z10 normally grandfathers projects underway for new requirements, the need to comply with 10 CFR 851 as implemented by this chapter supersedes that allowance; furthermore, compliance prior to startup ensures safety and is more cost-effective than program backfit after fluid introduction.

<sup>7</sup> For the applicability of ASME B31.3 see paragraph 300.1.1 of B31.3 regarding the content and coverage.

## 2.0 Section Overview

- A. This section instructs the process by which pressure systems and their components are to be certified for use. The key areas of this section are: ASME code requirements, configuration control, inspection and testing, design oversight, documentation requirements, and pressure systems accountability and traceability.
- B. As of the release of this document, ASME B31.12, *Hydrogen Piping and Pipelines Code*, had not been published. Although not invoked by 10 CFR 851 (2008), it is expected that B31.12 may be applicable to hydrogen processes at LANL and, when released, shall be evaluated by designers and system owners for applicability in the design, repair, modification, inspection, and testing of hydrogen systems in the same way that the other codes listed above are required. Until release of B31.12, the most applicable piping codes are B31.3, B31.8 and B31.8S (where the requirements are appropriate). Hydrogen systems built prior to the release of B31.12 are not required to be redesigned to meet the requirements of B31.12, but must meet the requirements of B31.3.
- C. Pressure safety programs in similar industries and the use of national standards were used in the generation of this program. Industries include: White Sands Test Facility (NASA) and Savannah River Site (DOE). Primary national standards and guidelines used: National Board (NBIC), Code of Federal Regulations (CFR), American Petroleum Institute (API), and the ASME Boiler and Pressure Vessel and B31 series codes.
- D. Contact the Chief Pressure Safety Officer ([CPSO](#)) for questions regarding the subject matter of this document, applicability, or interpretations.
- E. Deviations from this chapter shall be approved by the CPSO and Site Chief Engineer using the variance process found in ESM Chapter 1 Section Z10. Variance approvals shall be documented and maintained with the pressure system documentation package.
- F. This pressure protection program addresses five basic focus areas: procurement, verification, registration, inspection, and repair. These five areas are accomplished as follows:
1. **Procurement:** Vessels and relief devices must comply with the requirements of the ASME code. Where non-code stamped components are procured, compliance is verified through engineering calculations, testing, and inspection documentation that is in accordance with the most applicable ASME code. Procurements shall follow the guidance as defined in IP 330.1 (and NQA-1 where applicable).
  2. **Verification:** Engineering calculations, and FOD PSO walk-downs, and documentation verification. Documentation maintained in IRM repository.
  3. **Registration:** Each vessel and relief device entered into PassPort, and systems entered into certification database.
  4. **Inspection:** FOD PSOs perform walk downs of all pressure systems, and documentation to ensure compliance with the code.
  5. **Repairs:** Performed and documented, and inspected as defined by NBIC and ASME code.



### 3.0 Qualification Requirements

#### A. Pressure System Designers

1. Shall have any of the training, education, and experience with pressure systems as defined in ASME B31.3 Paragraph 301.1, verifiable through resume', peer review, degree, class certificates, or OJT records.
2. Shall be experienced in the use of the applicable code for design.
3. Shall have experience in pressure system fabrication.
4. Shall have experience in system maintenance and inspection as defined by the ASME Codes.

#### B. Pressure System Reviewers

1. Shall be able to obtain a copy of and be familiar with the most applicable code as required, as per system review.
2. Shall have a working knowledge of pressure system design, fabrication, and operation.
3. Shall have a working knowledge of maintenance and inspection requirements defined by the ASME codes.
4. Shall have an working knowledge of LANL Conduct of Engineering practices

### 4.0 Pressure Safety Committee

The Pressure Safety Committee (aka Ch 17 Technical Committee) is chaired by the CPSO (POC of ESM Chapter 17). Members are appointed by the CPSO and typically include the FOD PSOs and others from around the laboratory whom the CPSO may call upon to review and provide input as requested on: variances, deviations, and waivers; component or system designs that must deviate from ASME Code, revisions to ESM Chapter 17, and/or decisions concerning interpretations of the ASME codes.

SMEs are not permanent members of the pressure safety committee, but have experience in areas relevant to the topic of discussion is applicable. For example, a welding SME may be engaged on welding questions but their involvement is not required when evaluating a pressure system that will not be assembled by welding or brazing.

### 5.0 Definitions and Acronyms

**Alteration** – The change of a pressure-bearing component that changes the original design structure. Does not include the removal and replacement of components, but of the modification of the component itself (e.g., welding an additional port to a U-stamped vessel is an alteration) which is stressed when under pressure.

**ASME B31** - American Society of Mechanical Engineers Piping codes.

**ASME BPVC** – American Society of Mechanical Engineers Boiler and Pressure Vessel Code.

**Authorized Inspector (AI)** – An inspector regularly employed by an ASME accredited Authorized Inspection Agency in accordance with the requirements in the latest edition of ASME QAI-1.

**Category D Fluid** – A fluid service which is nonflammable, nontoxic, not damaging to human tissues, does not exceed 150 psig, and the design temperature is between  $-20\text{ }^{\circ}\text{F}$  to  $366\text{ }^{\circ}\text{F}$  [ASME B31.3]

**Category M Fluid** – A fluid service in which the potential for personnel exposure is judged to be significant and in which a single exposure to a very small quantity of a toxic fluid, caused by leakage, can produce serious irreversible harm to persons on breathing or bodily contact, even when prompt restorative measures are taken [ASME B31.3].

**Certification** – All requirements of this document have been met and CPSO or delegate has approved pressure system for use. Is not to be understood as an ASME or NBIC certification, it is only a permit to operate the pressure system, granted by the CPSO.

**Check Valve** – (see system interaction below) – A spring loaded poppet valve that has one flow direction to keep system contents from back flowing.

**Code Equivalent** – A Pressure vessel or other component that, through documentation, proves that the design meets all of the design, fabrication, test, and inspection requirements established by the applicable code, but does not have a code stamp and does not require a code certified Inspector.

**Code Non-compliance** – A violation of a national consensus code (e.g., ASME), or the lack of documentation demonstrating code-equivalent fabrication.

**Component** – For this program is the same as the definition of “piping component,” as defined in ASME B31.3 Para 300.2. Other LANL processes/programs also use this term to include items in a piping system which make up a system. For example: Boilers are an equipment item in a steam system (see also Sub-component, and System below). When entering data into PassPort this definition must be understood. Depending on the hierarchy, relief valves and vessels may be equipment, component, or sub-components in PassPort, but are not considered (by definition) subcomponents as such by the ASME Code. Acceptable acronyms for design documents, labels, and PassPort are listed in ESM Chapter 1 [Section 230](#).

**CPSO** – Chief Pressure Safety Officer – Technical Authority Having Jurisdiction for this chapter and thus the LANL Pressure Safety Program. Final approver in system certification. Is a subject matter expert in pressure systems design, will assist system owners with applicable codes for pressure system design. Reviews and approves waivers and equivalencies. May delegate certain functions to Pressure Safety Officers.

**Cryogenic Fluids** – Fluids with a normal boiling point below  $-200\text{ }^{\circ}\text{F}$ . Other fluids, (i.e.  $\text{CO}_2$ , refrigerants, etc.) that are not necessarily considered cryogenic, must be taken into consideration as having similar pressure hazards as that of cryogenics.

**DCF** – Design Change Form. See [AP-341-517](#). Used to make simple permanent modifications on configuration controlled structures, systems, and components (SSCs) in hazard category 2 and 3 nuclear facilities, and high and moderate hazard non-nuclear facilities, when the use of AP-341-518, Modification Traveler is not justified. Used when designs do not require significant or long term commitments of engineering and craft, the design is being performed by the System Engineer with minimum help from other engineering disciplines, and the modification primarily involves a single engineering discipline.

**DCP** – Design Change Package. See [AP-341-505](#).

**Deputy Chief Pressure Safety Officer** – Delegated by the CPSO. Has signature authority for final approval of pressure system documentation packages. To mitigate conflict of interest, if Deputy (or delegate) is a FOD PSO, that person may not sign as (Deputy/Delegate) CPSO on systems within their FOD.

**Design Pressure** – Design Pressure is that pressure determined by the designer, for which the system or component must operate at worst case conditions/temperatures during normal operation (see ASME Section VIII Div 1, Part UG-21 and B31.3 Para. 301.2).

**ECN** – Engineering Change Notice. See [AP-341-506](#).

**Engineering Calculation** – To be performed as defined in AP-341-605 on all pressure relief valves, and as required by the applicable ASME code.

**Engineering Services Division** – Performs or facilitates detailed calculations and other design functions to aid FOD PSO and system owners.

**ESM** – LANL Engineering Standards Manual (PD342)

**Examiner** – An individual with the training and experience commensurate with the needs of the specified examinations. It is the person who performs the quality control examinations and is performed by the manufacturer, fabricator, or erector. See ASME B31.3 Chapter VI, paragraph 341.

**Excluded Systems** – Pressure systems that are not considered applicable to this program. Examples include but not limited to: vehicle pneumatic systems, propane-powered vehicles, or garden irrigation systems.

**Facility Pressure System** – Any liquid or gas pressure system that is maintained by the facility operations director, or where the cost of maintenance or repair is paid for by the facility, not the program it supports. (e.g., building heating boilers, fire suppression system, etc). Normally found in utility rooms that provide building services.

**Fault condition** – Any failure caused by component failure, human error, chemical reaction, or environmental conditions that may cause an increase in pressure above the MAWP of the component or system.

**Flexible Element** – A flexible element of a pressure or vacuum system including hoses, used in place of a pipe or rigid metal tubing. Also referred to as flexible tubing or flex-hoses.

**Fluid** – A chemical in gaseous or liquid (or sometimes solid) state which can be pressurized or be the pressure source in a pressure system.

**FOD PSO** – Facility Operations Director Pressure Safety Officer. Is familiar with ASME code guidance, and performs system certification reviews (per this document) of pressure systems within the FOD. Not required to perform design calculations, but aids system owners in compliance to this procedure and the use of the ASME code. A FOD PSO can request an approved (by CPSO) alternate or designee to help perform the functions defined in this document upon approval of the CPSO.

**FS Categories** – Fluid service category which defines the inspection interval for both pressure vessels and piping (corrosion analysis, remaining life, etc). Fluid service is not equivalent to Fluid Category as defined by ASME B31.3. Methodology can be found in API 570 “Piping Inspection Code.”

1. FS1- Service fluids that are either flammable, radioactive, toxic, damaging to human tissue, or perform a credited nuclear safety function in a vital safety system.<sup>8</sup> Includes systems that are ASME B31.3 Category M fluid service -- or High Pressure fluid service if not barricaded to prevent injury from fluid and shrapnel (definition of High Pressure Fluid Service below).
2. FS2- Service fluids that are not FS1, and have either a design pressure and temperature above 150 psig @ 36°F or 275 psig @ 200°F, or design temperature below -20°F. This is generally equivalent to ASME B31.3 normal fluid service but allows slightly higher pressure at lower temperature (200°F).
3. FS3 – Service fluids that are neither FS1 nor FS2. This is equivalent to ASME B31.3 Category D.

**High Pressure Fluid Service** – Pressure in excess of that allowed by the ASME B16.5 Class 2500 flange rating for the specified design temperature and material group. There are no specified pressure limitations. See also Chapter IX of ASME B31.3.

**Hydraulic Systems** – Those systems which use an incompressible fluid as the pressure media to perform work. These systems normally include pumps, piping, pressure safety valves, and accumulators.

**Hydrostatic Test** – A test performed on a pressure vessel or system in which the vessel or system is filled with a liquid (usually water) and pressurized to a designated level.

**Inspector** – Verifies all required examinations and testing have been completed and to inspect to the extent necessary to be satisfied that the design of the pressure system conforms to all applicable examination requirements of the Code and of the engineering design (see ASME B31.3, Chapter VI, 340).

---

<sup>8</sup> A listing of VSSs is maintained on a Conduct of Eng [webpage](#). It includes only those safety class, safety significant, and defense-in-depth nuclear safety systems formally designated a VSS by the Engineering Managers of the nuclear facilities.

**Leak Test** –A pressure test used only to test system for leaks. Is not equivalent to ASME B31.3 Chapter VI. B31.3 refers to this term as a “Sensitive Leak Test.” Test pressure shall not exceed 90% of the system MAWP (see Pressure Qualification Test below).

**Lethal Substance** –Poisonous gases or liquids of such a nature that a very small amount of the gas or of the vapor of the liquid mixed or unmixed with air is dangerous to life when inhaled. This class includes substances of this nature, which are stored under pressure or may generate a pressure if stored in a closed vessel.

**Manufacturer's Service Rating** – The service rating (MAWP and design temperature) of a component, pipe, or tube available on the open market which has been designed and tested to a recognized guideline or military standard.

**Maximum Allowable Working Pressure (MAWP)** – Typically stamped on individual components (or sub-components) of a pressure system. Is the maximum permissible (internal or external) pressure of a pressure component (or system) when operated in its normal operating position at the designated coincident temperature specified for that pressure. It is the least of the values found for maximum allowable working pressure for any of the essential pressurized components of a pressure system as defined in ASME Section VIII Div 1, Part UG-98 (see also ASME Section VIII, Div 1 Part UG-23). Value is typically less than the component burst pressure by a factor of safety defined by the ASME Code.

**Maximum Operating Pressure (MOP)** – The maximum intended operating pressure, typically less than the MAWP to prevent premature system leakage through pressure-relieving devices.

**Minor Non-compliance** – A LANL self-imposed requirement that is not a violation of a DOE Policy Directive or a national consensus code. (Example: missing/loose pipe brackets, or unlabeled components).

**Mobile Pressure Containers** – Pressure vessels designed for travel on streets and highways; e.g., tube trailers, cryogen tankers, and other vessels mounted on trailers, trucks, etc. [ASME B&PV Code Section XII].

**Modification** – Any pressure system component change, addition, or deletion other than replacement of components with similar performance characteristics such as flow capacity and strength. This definition does not include alteration of pressure bearing components (e.g., welding additional ports to pressure-bearing component – see “Alteration”).

**Non-Conformance Report (NCR)** – Process defined in LANL Procedure [P 330-6](#). Initiated by system owners, FOD PSOs, or others when deficiencies require tracking and/or disposition. *At time of writing, this process was, at a minimum, applicable for code deficiencies or indeterminate conditions associated with an ML-1 or ML2 system or component.*

**Non-Destructive Examination (NDE)** – Examinations including visual examination, radiographic examination, ultrasonic examination, and dye-penetrant testing used to qualify the condition of a pressure vessel or component.

**Non-hazardous Fluids** – Any fluid or mixture that is nonflammable, nontoxic, and is not corrosive. Cryogenic fluids are considered hazardous.

**Normal Fluid Service** – A fluid service pertaining to most piping covered by the B31.3 Code but not subject to the B31.3 rules for Category M, Category D, or High Pressure fluid services.

**Operating Pressure** – A pressure less than the MAWP at which the pressure system is normally operated.

**Operating Temperature** – A temperature between the lower and upper design temperatures of the pressure system, or component.

**Out-of-Service System** – A system that is formally designated inactive or not in use.

**PassPort** – LANL's Computerized Maintenance and Management System software package that includes the Master Equipment List. Required by this pressure safety program for tracking relief valve testing and vessel inspections.

**Pilot-Operated Pressure Relief Valve** – A pressure relief valve in which the major relieving device is combined with and is controlled by a self-actuated auxiliary pressure relief valve (commonly used in hydraulic systems and some steam systems).

**Pneumatic Test** – A test performed on a pressure system or component in which a gas is introduced and pressurized to a designated level in a manner prescribed in the applicable code.

**Poly Tubing** – Term used for many types of flexible polymer tubing. Examples include Poly-Flo® and Tygon®.

**Portable Pressure Vessels** – Pressure vessels easily transported from one location to another but without mobile gear attached. Examples include portable dewars, Department of Transportation (DOT) compressed gas cylinders, and sample bottles (e.g. Hoke bottle, Swagelok sample cylinders).

**Pressure Pipe** – A relatively heavy-walled tubular fluid container/transporter that is normally attached or connected to fittings or components with threads or welds.

**Pressure Qualification Test** – A pressure test performed above the MAWP using a non-hazardous fluid to ensure the integrity of the pressure system, or component. For example, see ASME B31.3, Chapter VI. Typically for HVAC/Refrigeration systems this pressure is 130% (pneumatic) of the design pressure (ASME B31.5, Para. 538.4.2), and either 110% (pneumatic) or 150% (hydrostatic) of the design pressure for B31.3 systems. See also (as an example) ASME Section VIII Div 1 Part UG-99, UG-100, and UG-101 for further information.

**Pressure Relief Valve (PRV)** – Most common and preferred term for pressure protection valves at LANL used for a pressure relief valve which is actuated by inlet static pressure that opens in proportion to the increase in pressure over the opening pressure.

**Pressure Safety Valve (PSV)** – Also known as a Pressure Relief Valve (PRV). A pressure relief device that is designed to re-close and prevent the further flow of fluid after normal conditions have been restored.

**Pressure Tubing** – Different from “Pressure Pipe.” Is a relatively thin-walled tubular fluid container/transporter that is normally suitable for bending and is attached or connected by flared fittings, compression type fittings, or welding.

**Pressure Vessel** – Containers for the containment of pressurized fluids, either internal or external. Excluded are pipe runs; however, a vessel may be fabricated from a section of pipe if the construction conforms to ASME code requirements. For this program, storage vessels such as 55-gallon drums are not considered pressure vessels and shall not be pressurized by an external source.

**Programmatic Pressure System** – Any gas or liquid pressure system which is used for testing, manufacturing, research purposes, or used in support of testing, manufacturing, research processes. Maintenance or repair of these systems is paid for and/performed by the program, not the facility. Vessels and components that cannot be code stamped must be provided with documentation proving design is equal to or greater than the ASME code guidance in terms of testing, inspection, and over-pressure protection. Design and maintenance of these systems must comply with the most applicable ASME code (exception: see “Test Article”).

**Proof Test** – A pressure test performed to establish the maximum allowable working pressure of a vessel, system, or component thereof when the strength cannot be computed with a satisfactory assurance of accuracy. This test will be performed in a manner equivalent to one of the methods specified in paragraph UG-101 of the ASME Boiler and Pressure Vessel Code, Section VIII, Division 1.

**Relief Valve** – PRV designed for liquid or liquid mixed with steam or gas.

**Rupture Disk Device** – Also known as Burst Disk. A non-closing pressure relief device actuated by inlet pressure, which is designed to remain open after operation. The device performs its function by bursting a pressure-containing disk.

**Safety Relief Valve** – A pressure relief valve characterized by rapid opening or pop action or by opening in proportion to the increase in pressure over the opening pressure. Used for gases and steam.

**Safety Valve** – A pressure relief valve actuated by inlet pressure and characterized by rapid opening or pop action. Used on B&PV Section I steam systems.

**Set Pressure** – Set pressure is the value of increasing inlet static pressure at which a pressure relief device displays one of the operational characteristics as defined by opening pressure, popping pressure, start-to-leak pressure, burst pressure or breaking pressure.<sup>9</sup> Measured at the pressure relief valve inlet, at which there is a measurable lift, or at which discharge of a fluid becomes continuous. The terms open pressure, relief pressure, cracking pressure, and set points are equivalent when testing valves.

---

<sup>9</sup> ASME Section VIII, Division 1, 2007 edition, Footnote 61.

**Source Pressure** – The pressure supply source that provides pressure to a system. Examples include: Gas cylinder, pump, heated vessel (boiler), cryogen dewar, chemical reaction, etc. Is not regulated pressure.

**Stop Valve** – A valve that is installed between the piping or component being protected and its protective device (PRV) or between the protective device and the point of discharge. Although allowed by the ASME code, this design scenario is discouraged. Designs using stop valves in any manner that is not allowed by the ASME code must be reviewed by the CPSO for approval.<sup>10</sup>

**Sub-Component** – Term used by other LANL programs/processes. These will always be “piping components” as defined by ASME B31.3 para 300.2. For example: A boiler can be a component of a steam system, but the boiler itself is made up of sub-components (shell, tubes, PRV, etc.). Some subcomponent examples: relief valve, flex-hose, vessel, gauge, manual valve, flow-meter, pressure transducer, nozzle, orifice, regulator, etc. (see also ESM Chapter 1, Section 200).

**System** – Combination of multiple components (and possibly subcomponents) which together make a pressure system. Example 1: A steam system can be comprised of two main components: The boiler and the steam piping which runs throughout a building. Example 2: A gas chromatograph system may consist of a combination of components (or sub-components) such as: gas cylinder, manual valves, tubing, pressure transducers, flexible hoses, vacuum pump, and the GC.

**System Interaction** – Interactions among pressure systems that may cause a system to be over pressurized, or cause unwanted mixture of separate fluids, which necessitates the evaluation of all system interfaces (i.e., determination of check valve installation and placement). In extreme cases could warrant the use of dual check valves placed in series.

**System Owner** – The individual responsible for the overall operation, maintenance, design (code compliance), documentation, and/or construction of a pressure system. Technical decisions for the system are the responsibility of the Design Authority (ref. P340-2, Design Authority).

**Tank** – A container whose contents are maintained at atmospheric pressure or below 15 psig at all times, and cannot be pressurized above 15 psig, even through fault conditions.

**Test Article** – An excluded pressure system/component. A component or system of components provided by a vendor, or is part of a research and design deliverable. Is temporarily installed in LANL facilities exclusively for the purpose of being tested for data purposes, or destructive purposes. Included in this definition are those test articles that are being designed by LANL personnel, which are considered product, and must undergo numerous design changes, modifications, and alterations.

Examples of excluded test article systems include flight hardware such as: WR pressure components and systems (e.g., vehicle-specific flight-weight tritium reservoirs and associated flight-weight plumbing/components), or space vehicle pressure components and systems (e.g., vehicle flight-weight propulsion or hydraulic systems/components). However, pressure systems that support the design, testing and/or evaluation of such hardware are not excluded.

---

<sup>10</sup> See ASME B31.3 paragraph 322.6.1



**Vacuum System** – An assembly of components which may include vessels, piping, valves, relief devices, flex hoses, gages, etc., operated with the internal pressure reduced to a level less than that of the surrounding atmosphere. Some vacuum systems can be subjected to a positive pressure because of vacuum break and purging capabilities.

**Vacuum Vessel** – A vessel operated with the internal pressure reduced to a level less than that of the surrounding atmosphere.

**Vendor-Owned Equipment** - Pressure vessels and/or equipment owned by a vendor to transport, store fluids or gases, or to perform a support function on LANL property.

**Vessel** – For the purpose of this program, any pressure chamber, regardless of formed heads (e.g., dished, concave, convex, etc.) or cylindrical shape, which has been installed into a pressure system that can, through fault conditions, be pressurized above 15 psig.

## 6.0 General Program Statements

### A. Basic program requirements

1. Programmatic pressure systems, regardless of presence of vessels, where the source pressure is greater than 15 psig (including cryogenic, vapor pressure, chemical reaction and/or pump pressurized systems) shall be designed to meet the requirements of the applicable ASME BPV and ASME B31 codes or CPSO-approved equivalent. These systems shall be subject to the certification requirements of this section.
2. Facility pressure systems (power boilers, heating boilers, shop supply air, etc) where the source pressure or pressure generated is greater than 15 psig are also subject to the certification requirements contained in this document (ASME Section IV boilers are not exempt).
3. Mobile and portable pressure systems that are 4 psig or greater (as defined by ASME Section XII) are also included in this program. These include tube trailers, vehicle-mounted vessels, and skid-mounted vessels.
4. Pressure systems shall have documentation proving compliance with the ASME code, or indicating excluded status, where the definition of excluded is defined in this document.
5. Non-excluded pressure systems shall have a documented design review by a FOD PSO (or delegate), and approved by the CPSO to maintain operation. Any system found operating without approval must be taken out of service, vented/drained, and disconnected from the pressure source.
6. New pressure systems shall be certified according to this document prior to use.
7. Pressure system owners shall notify the FOD PSO of existence of existing, new, or modified pressure systems.

8. Request for variance from code compliance must be submitted through CPSO, for review. Requests for variance could include systems where installation of pressure relief devices is impossible, or where systems are contained within “blast” containment devices, which mitigate the potential of personnel injury, should the pressure system fail. Variances shall be reviewed for applicability against ASME Code Case 2211, and ASME Section VIII, Division 1, Part UG-140.
9. The terms “inspection” and “certification” in reference to FOD PSO, or other “walk-down” activities, in this section, does not constitute Authorized Inspector inspection process except where specifically noted.
10. Where this document refers to the term “Pressure system certification tracking database,” this reference is not the CMMS/MEL/PassPort Database system. Rather, it is via a Microsoft SharePoint [site](#) database used by CPSO/PSOs for maintaining an inventory of all pressure systems, configuration of pressure systems and tracking of pressure systems certification only, not for tracking of vessel, and relief valve inspection due dates.
11. Modifications to pressure vessels and pressure systems must follow DCP, ECN, or DCF formality as defined in AP-341-505, AP 341-506, or AP-341-517, whichever is applicable to the facility and program type. These Administrative Procedures are on the Conduct of Engineering AP [webpage](#).
12. Temporary facility modifications shall comply with AP-341-504, where applicable to the facility. Programmatic systems shall prove compliance by documenting the temporary modification, and updating the IWD to ensure any new hazards have been controlled. Documents describing the design change, and hazard mitigations shall be reviewed by all those who originally signed the IWD, or their designee to approve the temporary design change. Signed copies of design review, including any sketches, and calculations, shall be maintained with the controlled copy of the IWD.
13. Design document reviews shall be performed as defined by [CoE](#) AP-341-620 or 622.
14. Classified systems are not excluded from this program. Classified data must be handled appropriately.
15. Captured vent or drain systems that contain hazardous, lethal, or considered to be Category M fluids (as defined by ASME B31.3) that are 15 psig or less, and are not open to the atmosphere at all times are not excluded from this procedure.

## 7.0 Excluded Pressure Vessels, Relief Devices, and Systems

### A. Pressure Systems

NOTE: Pressure systems, regardless of whether excluded or in this program, must be designed with appropriately sized pressure relief/vent systems. For example, water holding tanks filled by pumps are considered excluded from this program, however, if the original pump on the water tank is replaced, a design review should be performed to ensure the pumping capacity of the new pump will not “out-flow” the capacity of the existing vent system.

1. Supplier-owned pressure systems except for leased, LANL-operated equipment which requires FOD PSO review for proper valve sizing and maintenance. Procurements are required to conform to this review.
2. Facility water and sewer systems such as drinking fountains, faucets, garden hoses, lawn sprinkler systems, etc, not governed by ASME BPV or B31 Codes.
3. Packaged refrigeration (to include HVAC and refrigerators) units bought commercially, off-the-shelf, without modification
4. Vent or drain systems that are open to the atmosphere at all times.
5. Facility water wells, water tanks, and water distribution piping
6. Welding brazing or soldering equipment covered by other standards
7. Commercially-available, prepackaged, off-the-shelf, laboratory equipment such as gas chromatographs and mass spectrometers. However, when connected to a pressure source, the associated hardware is not excluded, and must be designed per the most applicable ASME Code.
8. Commercially-available alternative fuel vehicles, such as propane-powered vehicles (CFR 49)
9. Pre-packaged, unmodified, and off-the-shelf hydraulics.
10. Fire protection and suppression pressure systems covered by NFPA Codes and Standards (e.g. NFPA 13 and NFPA 25)
11. Gloveboxes alone are excluded from this program. However, purge and other pressure systems that interface with gloveboxes must have pressure relief that meets the requirements of ASME Section VIII, Division 1 Part UG-125 to keep the glovebox from being overpressurized.<sup>11</sup>

---

<sup>11</sup> Gloveboxes should be protected from over pressurization with bubblers or other pressure relief device which exits through a vent system. Glove failure (popping off), window seal failure, or other such failures are not acceptable pressure relief methods.

12. Air compressor units meeting all the following:
  - a. System pressure relief device does not exceed 150 psi
  - b. Tank(s) are less than 6 " I.D.
  - c. No alterations have been made to the unit
13. Test Articles (as defined in Section 5.0 - Definitions) and Test Article Systems must be shielded to prevent possibility of personnel injury). However, pressure systems that support the design, testing and/or evaluation of such hardware are not excluded. All research and development systems that must undergo continuous design changes must be reviewed by the CPSO.

#### B. Pressure Vessels

1. Tanks and low pressure vessels that cannot accumulate above 15 psig.
2. Non-code building service or heating water surge tanks under 50 gallons.
3. Although not specifically included by the requirements of 10 CFR 851, vessels regulated by the Department of Transportation (D.O.T)<sup>12</sup> must follow the recertification frequency intervals as defined in this document.
  - a. Relief valves attached to such D.O.T vessels must follow the test/replacement schedule as defined in this document.
  - b. D.O.T. vessels are not required to be entered into MEL or Passport
  - c. D.O.T. vessels must be maintained within inspection interval dates.
4. Pressure vessels in vehicle pneumatic and hydraulic systems.
5. Drained, depressurized, and vented out-of-service pressure systems that are labeled as such.
6. Self-Contained Breathing Apparatus (SCBA) air cylinders.
7. Portable eyewash stations and non-refillable, portable cylinders, and soda and syrup containers covered by NSDA (Nat'l Soft Drink Assoc) or CFR 49.

**NOTE:** The following vessels cannot be excluded without acceptance by site Chief Pressure Safety Officer or delegate:

1. ASME Code-stamped vessels regardless of application<sup>13</sup>

---

<sup>12</sup> Relief valves on DOT vessels are not excluded from this program, and must be maintained as defined in this document. Vessels must be within their inspection date as defined in the DOT, UN/IM section of this document.

2. Any vessel that can accumulate above 15 psig
3. Pressure containers that rely solely on interlocks to limit the pressure to less than 15 psig<sup>14</sup>
4. Vessels or tanks either permanently or temporarily connected to a pressure source/interface that is 15 psig or greater
5. Vessels in vacuum systems or that can be externally pressurized

**C. Pressure Relief Devices**

1. Rupture disk and fusible plugs on DOT gas cylinders.
2. Pressure relief devices on vehicle pneumatic and hydraulic systems.
3. Pressure relief devices on drained, depressurized, and out-of-service vessels.
4. Non-metallic, non-Code pressure relief valves on portable eyewash stations that comply with the NSDA standard.
5. Fusible plugs on refrigeration equipment that conforms to ASHRAE 15.
6. Pressure relief devices that do not provide a pressure protection function.
7. Pressure relief devices on transformers.
8. Hydrostatic bubblers, e.g., on gloveboxes

**D. Calculations**

1. Design calculations are not required for package systems (e.g. boilers, or air-compressors) built by a reputable manufacturer that are not of unique design, with a retrievable model number. Such package units must be readily found in a catalog, or manufacturer's inventory, with proven design reliability. However, manufacturers data reports (e.g. U-1, U-1A), and system drawings (to include schematics) must be maintained in the pressure system documentation package.
2. Modification or an alteration to the above package systems voids this exemption. Drawings must be updated, and calculations must be performed to prove compliance with the applicable code.

---

<sup>13</sup> E.g., modifications could potentially void the code stamp; this needs to be managed

<sup>14</sup> See Code Case 2211 and ASME Section VIII, Division 1, Part UG-140

## 8.0 System Identification Tag

### A. System Identification and Inventory Method

1. Certified pressure systems shall be marked with the following system identification tag, which will be supplied by the CPSO. This tag is not meant for identification of pressure vessels or other pressure system components. It is a system identification and status tag.
2. The purpose of this tag is to provide a means of identification (inventory) and status of the system. The identification number on this tag shall match the pressure system documentation package identification number. This system identification number is unique to each individual system.

*Guidance: The tag should be attached using stainless lock-wire anywhere on the system in open view, where the most visible portion of the pressure system is located. To be attached by the FOD PSO or designee.*

3. Tags shall not be placed on removable components such as gas cylinders. Further, tags may not be removed from the system without notifying the CPSO.
4. Tag indicates system status, inventory number, and certification interval. Does not indicate vessel inspection due date, or relief device due date.
5. Status indication “stickers” may be only be generated by CPSO-approved method (i.e., system owner may not print their own “stickers”). System certification intervals will be tracked through certification tracking database.

*Guidance: Status indication “stickers” need not have adhesive backing, and may be printed on normal printer paper.*

6. “Inactive” stickers shall be issued for those pressure systems that have been removed from the pressure source, are not designated to be disassembled, and are considered to become operational in the future. Inactive systems must be physically disconnected from the pressure source.
7. “Active” stickers shall be issued for those pressure systems that have been certified and approved to operate as per the requirements of this document.

*Guidance: “Stickers” should be covered with UV-resistant tape such as Kapton® or other similar transparent, UV-resistant tape, after being applied to the identification tag.*

8. Damaged or lost stickers can be replaced through request to the CPSO, who will verify certification status in the pressure systems database prior to issuing a new sticker.

# SYSTEM IDENTIFICATION AND CERTIFICATION TAG

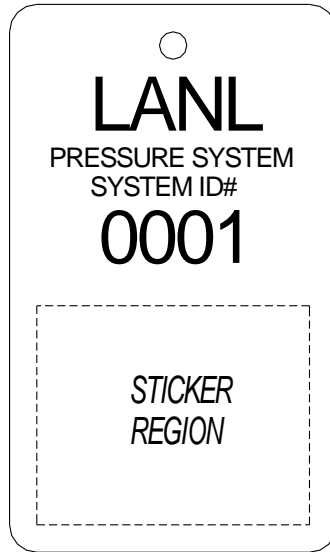

## STICKER EXAMPLES

<b>ACTIVE</b>
INSPECTION DATE _____
DUE DATE _____
CERTIFYING PSO _____

<b>INACTIVE</b>
INACTIVE DATE _____
CERTIFYING PSO _____

### 9.0 Pressure System Certification Process

#### A. Process Flow Chart

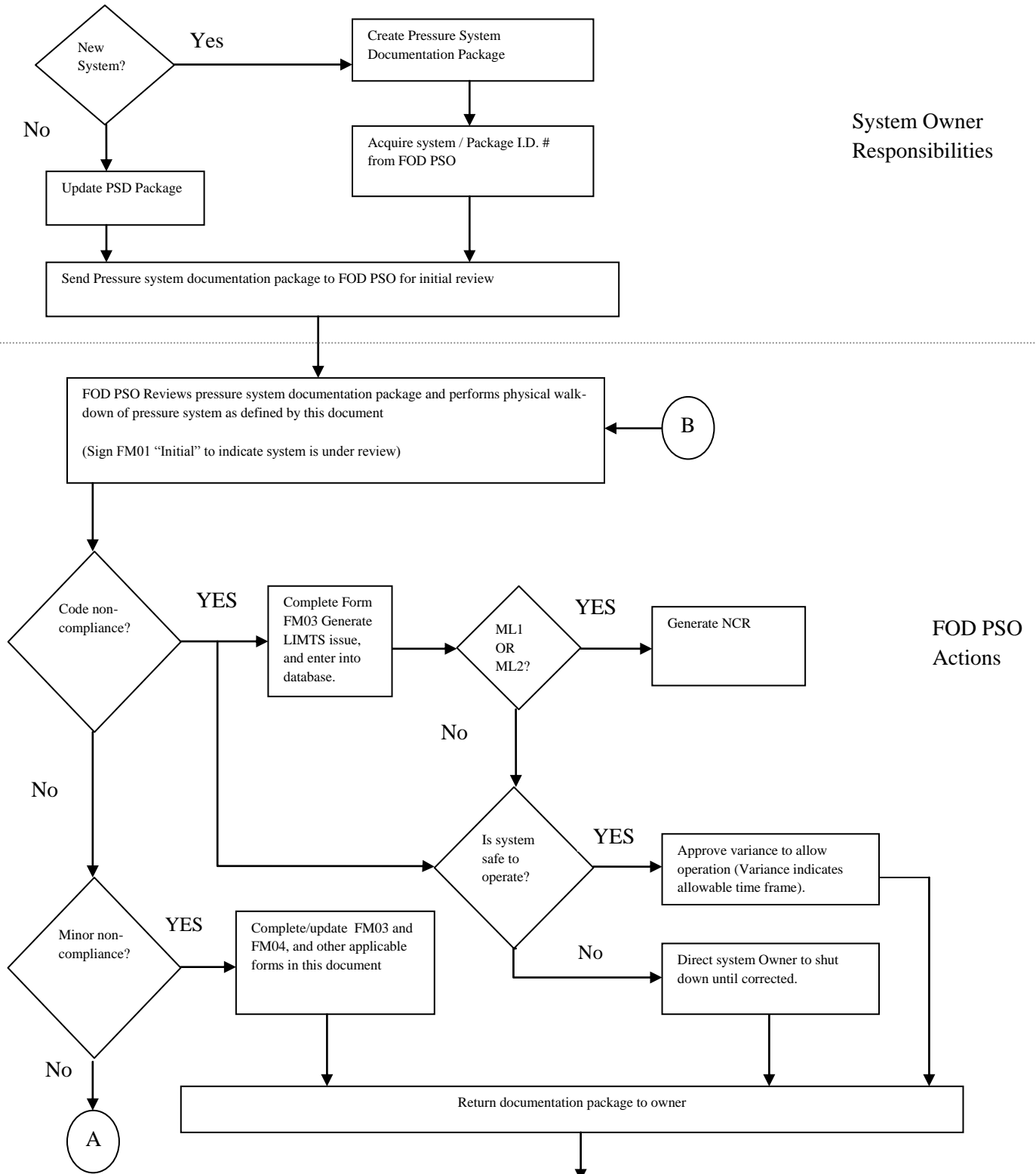



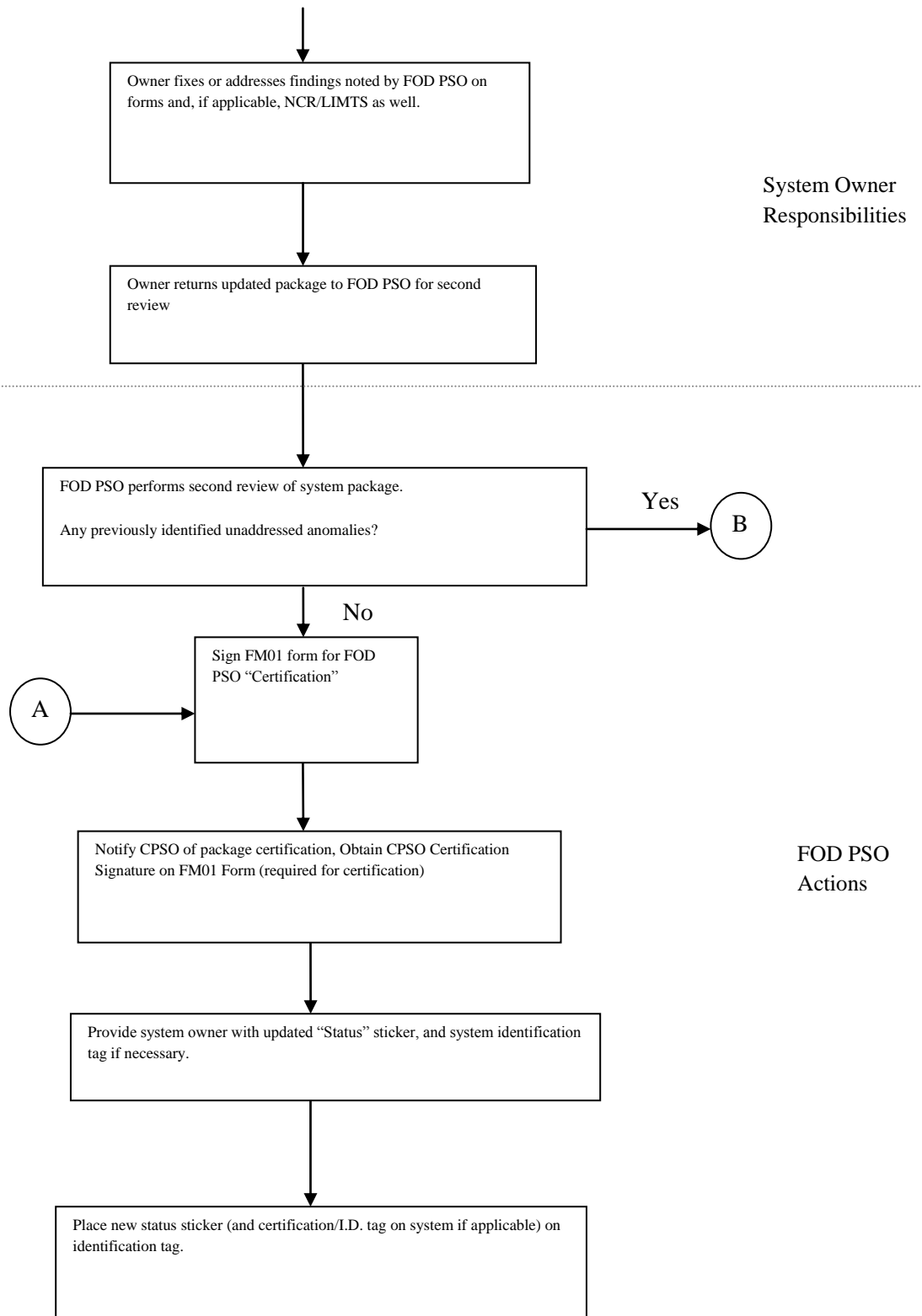

**B. General**

1. The certification process is the initial and follow-up reviews of pressure systems by the FOD PSO (or delegate). The program also includes periodic recertification to ensure continued compliance with the program (e.g., configuration control, documentation accuracy, and compliance with the codes). It is not an ASME certification. It is merely a permit granted by the CPSO which authorizes the pressure system to be operated.
  - a. Programmatic pressure systems are subject to an annual certification process<sup>15</sup>. All modifications/alterations to programmatic pressure systems must be documented and maintained current (e.g., drawings must be updated at every configuration change, proof of approval by FOD PSO of changes documented, documented weld inspections, etc.)
  - b. Where owning organizations are sufficiently implementing Conduct of Engineering configuration control practices (DCP, ECN, etc) as determined by the Conduct of Engineering Office, systems shall be recertified at intervals determined by pressure relief device recall due-dates. E.g., if a PRV must be tested or replaced every 2 years, then the pressure system must be recertified every 2 years (recert ideally done concurrently with the PRV maintenance activity, but only requirement is on same frequency).
2. New and modified pressure systems shall not be operated until certified.
  - a. Pressure systems (but not excluded pressure systems) regardless of Fluid Service Category or relief device/vessel inspection intervals (FS1, FS2, and FS3 inspection intervals as defined by this document) shall be reviewed in intervals as defined by this section to verify documented configuration and documentation traceability.
3. If deficiencies are found during the review process (or any other time), they shall be identified on Form FM03 and FM04, as applicable (see attached forms for examples).
4. Whenever Code non-compliance deficiencies are found on active ML-1 or ML-2 systems, the FOD PSO shall initiate a Nonconformance Report (NCR) when required by LANL Procedure [P 330-6](#).
5. All Code non-compliances (regardless of Management Level) must have LIMITS actions generated.
6. Pressure systems that are overdue for their recertification may be operated only by a recertification waiver (variance) granted by the FOD PSO. Recertification waivers shall not extend beyond 3 months of the recertification due date. Recertification waiver shall be maintained in the pressure system documentation package.
7. Existing pressure systems shall be evaluated to the latest revision of this document and the code of record of the system's construction (COR defined in ESM Ch 1 Z10). If original

---

<sup>15</sup> Until Conduct of Engineering CM processes per PD341 have been fully implemented by programmatic organizations.

code or standard is unavailable, newer editions may be used. Minor Non-compliances and Code Non-compliances should be identified during the recertification process and documented.

8. Inactive, deactivated, or other non-active pressure systems may not be operated in order to achieve active status (e.g., perform leak checks) until after the FOD PSO has reviewed the system design, configuration, and documentation package.
9. The CPSO will review and, if acceptable, approve any deviations from this Chapter along with Site Chief Engineer per ESM Ch. 1 Section [Z10](#). Deviation approvals shall be documented in the pressure system documentation package.
10. Legacy FS1 and FS2 fluid systems that have not had formal vessel inspections (NBIC/AI) shall be reviewed by the CPSO for temporary de-rating of MAWP until a formal inspection has been completed.
11. Any system found to be out of compliance with this document, or found to be in an unsafe configuration in the opinion of the FOD PSO, must be reported to the system owner and the FOD. Upon direction from the FOD PSO, the owner shall de-pressurize the system and fix any anomalies found by the FOD PSO prior to certification as defined in this section.

#### C. Preparing a New or a Modified Pressure System for Certification

1. If system is new, system owner ensures system is constructed and tested in accordance with the requirements of the sections of this ESM chapter, and applicable ASME Codes.
2. System Owner ensures that required forms and quality documents are placed and maintained in the pressure system documentation package and the package is identified by the identification number given by the PSO, as generated by the certification tracking system database.
  - a. See Table 17-1, Documentation Table, near the end of this document for required documentation that needs to be maintained and kept updated in the pressure systems documentation package.
  - b. Applicable forms in this document shall be completed and placed into the pressure systems data package.
3. System Owner requests a System and Documentation Package review from a FOD PSO.

NOTE: No pressure system may be operated until CPSO has certified its design.

4. The FOD PSO reviews the pressure system documentation package and performs a system walk down, as follows:

NOTE: The FOD PSO (or system reviewer) must keep an eye out for any hazards during the walk-down that may exist in the system design such as: material incompatibility, non-intrinsically-safe electrical

components near flammable chemicals, inadequately braced lines, etc. Such observations or concerns shall be noted and accounted for in the reviewer's write up.

- a. Adds any Minor Non-compliances noted onto FM04 "Minor non-compliance" form.
  - b. Adds any Code Non-compliances noted onto FM03 "Code non-compliance" form.
  - c. Reviews and approves the Documentation Requirements Table 17-1.
  - d. The pressure system documentation package is checked and verified for accuracy.
  - e. The actual pressure system is walked down to verify accuracy of package contents.
  - f. Completes (signs and dates) Minor Non-compliances and Code Non-compliances forms, and then inserts the forms into the pressure system documentation package.
  - g. FOD PSO Generates NCR's for all code-non compliances found on ML-1 and ML-2 systems.
  - h. FOD PSO generates LIMTS actions for all code-non compliances found.
  - i. The FOD PSO then signs FM01 "Pressure System Certification Status Form" (Initial Review) and returns the documentation package to the system owner.
5. System Owner updates the documentation package and pressure system based on FOD PSO review and comments as found on forms FM03 and FM04.
  6. System Owner submits package back to FOD PSO for second review.
  7. If the documentation Package and pressure system is acceptable, the FOD PSO then signs the Pressure System Certification Status Form (Certification) Form FM01, and delivers the package to the CPSO for final review and approval.
  8. If there are no Code Non-compliances, the CPSO then certifies the system as "Active" for a period not to exceed the review cycle interval by signing the Pressure System Certification Status Form (Form FM01) and updating the certification tracking database.
    - a. The FOD PSO issues the Active sticker and, if necessary, an Identification Tag to the System Owner if system is not already tagged.
    - b. The System Owner attaches the sticker to the Identification Tag and, if necessary, installs the Identification Tag on the pressure system.
    - c. Package stored in IRM repository designated by FOD.

**D. Recertifying an Existing Pressure System for Use**

1. The purpose of this recertification process is to ensure that the system configuration has not changed from previous certification and that all scheduled preventive maintenance has been completed.
2. FOD PSO notifies System Owner that a pressure system is due for recertification.
3. FOD PSO Reviews pressure system documentation package, drawings, forms, and current configuration, to ensure configuration has not changed since last review.
4. FOD PSO ensures preventive maintenance activities have been performed (by reviewing tags, PassPort, documentation packages, etc.).
5. If no discrepancies are noted then system is recertified and updated Certification Sticker can be placed on the Identification tag to reflect certified status. Pressure system database updated to reflect certified status.
6. If anomalies are noted, perform “Preparing a New or Modified pressure system for certification” process as defined in this document.

**E. Tracking of Pressure Systems Annual Recertification Status**

1. The CPSO will oversee the pressure systems certification tracking database. However, the FOD PSO is responsible for inputting the data.
2. The FOD PSO’s will verify on a monthly basis the recertification status of pressure systems using the Pressure Systems Certification Tracking Database. If systems are found to be overdue, a report will be sent out informing the FOD PSO and System Owner that a system is overdue in their area and will be subject to deactivation if not recertified within 3 months after due date.

**F. Conflict of Interest**

1. If a FOD PSO or CPSO owns or uses pressure systems, they may not review or approve their own systems. They must be reviewed by an uninvolved PSO.
2. If a FOD PSO has CPSO signature authority they may not sign as CPSO for pressure system documentation package approvals on systems within their own FOD.

**G. Documenting Non-conformances**

1. Forms FM03 and FM04 shall be completed for all non-conformances. In addition, non-conformances arising from deficiencies or indeterminate conditions for ML-1 and ML-2 systems (at a minimum) are documented on NCRs.
2. Code non-compliances found on any system (regardless of Management Level) shall be immediately corrected or system formally inactivated by PSO/CPSO. Where neither is

possible, corrective actions will be entered into LIMTS (LANL Issues Management Tracking System) by CPSO or delegate.

3. *A copy of the non-conformance report (Form 2082) should be maintained in the system documentation package.*

#### H. Deactivating a pressure system

1. The responsible System Owner safes the particular pressure system which includes:
  - a. Removing hazardous materials from the system.
  - b. Reducing system pressure to ambient
  - c. Disconnecting the system from all pressure sources.
2. The FOD PSO reviews the system and if the deactivation is acceptable updates the certification tracking database with date of deactivation.
3. The FOD PSO submits note into pressure system documentation package that system is not active, and maintains package in IRM document control repository.
4. The FOD PSO annotates the Pressure System Certification Status Form with the date the system became inactive and either removes the Identification Tag, or places "INACTIVE" sticker on the identification tag on the pressure system.
5. FOD PSO informs the CPSO that the pressure has been deactivated, and inactivates the related components in PassPort.
6. CPSO or delegate updates certification tracking database showing the system as inactive.
7. If system is to be disassembled perform the following:
  - a. Notify IRM that documentation may be archived.
  - b. The database tracking system entries shall be archived or deleted.
  - c. The identification tag shall be returned to the FOD PSO so that it can be used on a future system.

## 10.0 Design and Documentation

### A. Calculations

1. Calculations and documentation shall be performed/provided using U.S. customary units (psi, inches, gpm, scfm, °F, lbs, etc.).<sup>16</sup>
2. Calculations, including welding calculations, shall be performed per [AP-341-605](#), *Calculations*, and ESM Chapter 1 Section [Z10](#) (re: Design Output Documentation) and shall be maintained in the pressure system documentation package.
3. Relief devices on new systems (other than Excluded) shall have sizing calculations performed showing that the capacity of the designated relief device maintains system pressure at or below 110% (or other percentage defined by ASME Section VIII, Div 1 Part UG-125) of the system MAWP.<sup>17</sup>  
*Guidance: A FileMaker Pro program is available to perform relief device sizing calculations, as is training material on the process to be followed, [here](#).*
4. Where system flow characteristics cannot be determined through calculations, capacity of the relief system shall be verified by performing an in-place flow test of the relief devices upon completion of fabrication as defined in ASME PTC-25 paragraph 4.3.3 and API 521 for pressure systems with supplied pressure. Flow test shall be documented and maintained in the pressure system documentation package.

**Note:** Any existing pressure system that does not have sizing calculations on relief devices must either perform and document an in-place flow test for existing relief valves, or generate flow capacity calculations. The calculated relieving capacity of pressure relief systems utilizing rupture disks as the sole relief device shall not exceed a value based on ASME BPVC Section VIII Division 1, Part UG-127 (a)(2).

### B. Cryogenic systems

1. For systems using ball valves, the ball must have a pressure relief hole designed into the ball to prevent over pressurization inside the ball cavity due to thermal expansion when the valve is in the closed position.
2. All valves and components shall be designed and approved for use by the manufacturer for cryogen media.
3. Polymer-lined flexhoses shall not be used.<sup>18</sup>

---

<sup>16</sup> Relief devices are rated in US units.

<sup>17</sup> See ASME Section I and IV for boiler-specific capacity allowances

<sup>18</sup> The extreme low temperatures will cause the hoses to become brittle, increasing the risk of rupture and leakage

4. Flexibility analysis (as defined in the most applicable piping code)<sup>19</sup> shall be performed on rigid piping to ensure adequate strain relief is designed into the assembly due to thermal contraction.
5. Soft goods in components must be compatible with the cryogen fluid, and be suitable for both the temperature and pressure. (Example: Many PTFE material combinations are compatible with hazardous fluids, yet maintain a seal at cryogenic temperatures, at different pressure ranges).

### C. DOT vessels

1. DOT vessels that are greater than 6" I.D. and are permanently installed in a pressure system must either maintain their DOT inspection intervals or, if it cannot be removed for recertification, shall be evaluated as ASME equivalent as follows:
  - a. The material specification of the vessel shall be determined as listed in the appropriate 49 CFR 178.xx cylinder specification (e.g., material specification for a 3A cylinder is listed in 49 CFR 178.36)
  - b. Using the appropriate maximum allowable stress for the material (at temperature) found in ASME BPVC Section II, Part D (matching the material specification of the DOT Cylinder).
  - c. Perform the ASME pressure calculations as described in Section VIII, Div 1, Part UG-27 or UG-28 as appropriate.
  - d. Maintain a copy of the calculations in the pressure system documentation package indicating the vessels' revised MAWP rating.
  - e. The vessel shall be entered into Passport and shall be periodically inspected per the appropriate FS Category for internal and external inspection intervals.
2. All other DOT vessels must maintain their inspection and certification intervals, with the due date of certification clearly identified on the vessel.

### D. Drawings and sketches

1. At a minimum, non-excluded pressure systems shall have accurate system schematics providing information of fluid flow paths, and system interactions of all wetted/pressurized components in the fluid path.

---

<sup>19</sup> For example see B31.9 Chapter 2 part 5 or ASME B31.3 paragraph 319.



2. System schematics shall ultimately be in accordance with ESM Chapter 8, Appendix I, “PFD and P&ID Diagrams.” PRV sizing calculations may be performed from accurate, dimensioned sketches.
3. Drawings and sketches shall comply with [AP-341-608](#), Engineering Drawings and Sketches.
4. Fluid components shall be identified using the identification system established in ESM Chapter 1, [Section 200](#), “Numbering and Labeling”.
5. Diameters, wall thickness, and material type of all tubing and piping used in the system shall be shown.
6. Sketches specific for relief device calculations shall show all dimensions required to generate calculation.
7. Pressure safety devices: Maximum pressure setting shall be shown. Note that the actual setting of the device in the system may be lower than the drawing maximum set point.
8. Pressure regulators: The following shall be shown on the system schematic:
  - a. Maximum operating inlet pressure, and operating outlet pressure (not to be confused with MAWP)
  - b. Pressure regulator (Cv) flow rate coefficient is not required to be shown when a smaller orifice is installed upstream or immediately downstream of a pressure regulator, or when tubing I.D. before (or immediately after) the regulator is less than regulator flow area. It is good practice to show Cv in these cases.
9. Pressure gages and transducers: Pressure range shall be shown. This is not to be confused with MAWP.
10. Vessels: MAWP as rated by ASME code stamp or alternative calculations based on wall thickness evaluation shall be shown.
11. System MAWP including new MAWP downstream of a pressure-controlling component shall be shown.
12. Inside diameter of orifices shall be indicated.

#### E. Finite Element Analysis

1. Use of computer software (e.g., Cosmos, NASTRAN, Pro/Mechanica, Ansys, Algor, custom shells, etc.) to perform analysis of pressure systems and components is acceptable in performing engineering calculations; however, software must be verified and validated as defined in DOE O 414.1C (or later), *Quality Assurance*, including use within established bounding conditions and on operating systems for which the specific release (version) was tested.

2. Finite element analysis and computer calculations shall follow ESM Chapter 1 - General Section [Z10](#) "Design Output Requirements".

**F. Fitting and Fastener Assembly**

1. Shall comply with one of the following
  - a. Manufacturer standards based on the joint design and all materials of construction.
  - b. A published specification or controlled standard
  - c. Special calculations by the designer

**G. Flexible Hoses and Tubing**

1. All preassembled flexible hoses shall be procured from the manufacturer with the MAWP stamped, etched, or tagged on the hose or end connectors indicating the maximum allowable working pressure of the assembly.
2. Flexible hose assemblies without manufacturer's MAWP indicated on the hose/flexible tubing shall not be used on non-excluded pressure systems.
3. Hoses used for cryogenic service shall be convoluted stainless steel or specifically designed for such service.
4. Long flexible hoses shall be restrained every six feet, and/or at every connector where multiple flexible tubing/hoses are connected in series.
5. Consider material compatibility per NFPA 30 and 45
6. Flexible "poly-flo", plastic and rubber hoses/tubing shall not be used for the conveying of flammable gases and flammable liquids per NFPA 30 27.3.1 and NFPA 45 10.2.
7. Rigid tubing shall be used in place of long lengths (greater than 3 ft) of permanently installed "Poly-Flo" or similar flexible tubing that does not require the function of which to be flexible.
8. Flexible hoses shall be installed and used in such a manner as to prevent kinking and to minimize torsion, axial loads, twisting, and abrasion.

**H. Fluid Category Determination**

1. The CPSO shall make the final determination of fluid category for all systems if there is any question. Determination of fluid category shall be determined using ASME B31.3 (e.g., Appendix M, Figure M300).

2. A piping system will be considered “High Pressure Fluid Service” and shall meet the requirements of ASME B31.3 Chapter IX if the design pressure is in excess of that allowed by the ASME B16.5 Class 2500 flange rating for the specified design temperature and material group. There are no specified pressure limitations.
3. Pressure systems (including repairs or alterations) with fluids identified as “lethal substance” shall comply with the following:
  - a. Pressure vessels shall be designed and constructed per ASME Section VIII “lethal substances.”
  - b. Piping systems will comply with the code by using the flow chart (figure M300 from ASME B31.3) to determine fluid media requirements (Category M vs. Normal).
4. Systems designated as Category M fluid service shall be designed and tested per ASME B31.3, Chapter VIII, “Piping for Category M Fluid Service.”
5. For further guidance see LANL’s “B31.3 Process Piping Guide,” Guide D20-B31.3-G.

#### I. Gas Cylinder Pressure Systems

1. Pressure systems utilizing pressurized cylinders as the pressure source shall meet all the applicable requirements of this document, including certification.
2. Pressure relief devices incorporated integrally into the design of pressure regulators do not perform a pressure protection function for downstream components, and shall not be considered as sufficient pressure relief.
3. Cylinders shall be braced, chained, in place to prevent toppling.
4. Gas cylinders shall have a pressure safety manifold system incorporated into the design after the regulator as shown below:

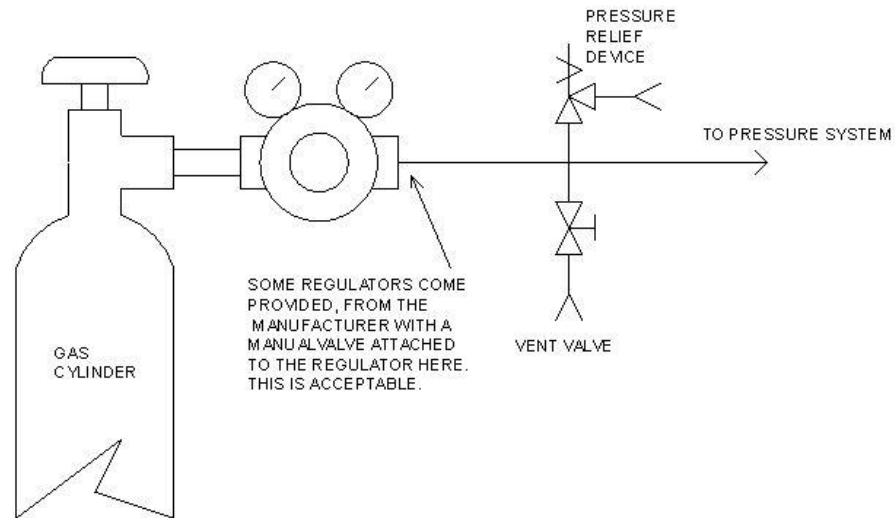

5. Where specific flow requirements are not a required function of the fluid flow, the installation of flow-reducing orifices is highly recommended to slow the flow rate of gas caused by failure of a regulator, or operator error.
6. Open flow systems (e.g., purge systems) that are not designed for and cannot accommodate full bottle pressure/flow rates shall utilize flow reducing orifices.
7. Pressure systems that are not “open flow” at all times, but require the use of RFOs, shall have appropriate pressure relief installed in the appropriate location(s) in the pressure system.
8. Pressure systems that are designed in accordance with the applicable ASME code, that are capable of withstanding the full gas cylinder pressure are not required to have pressure relief. Such cases must be proven to be designed per the ASME code, and shall be evaluated against Code Case 2211 and ASME Section VIII, Division 1, Part UG-140. Such applications shall be reviewed by the CPSO.

#### J. Hydrogen and Flammable Fluid Pressure Systems

1. Pressure systems containing such fluids shall be designed and evaluated against the requirements of ESM Chapter 10, *Hazardous Process*, and its appendices.
2. Systems containing hydrogen shall be evaluated for hydrogen embrittlement.
3. Bonding and grounding shall be evaluated for storage vessels and systems containing such fluids.
4. Electrical components (solenoid valves, power strips, electrical control cabinets) shall be intrinsically safe when required by the NEC.

**K. Labeling and tagging of components**

1. All components in a pressure system shall be tagged or labeled in accordance with the P&ID or system schematic and ESM Chapter 1, Section 200, "Numbering and Labeling."
2. Physical labeling must match the system schematic, and vice versa.

**L. Liquid lock**

1. Provisions shall be made in the design either to withstand or to relieve the pressure increase caused by heating of static fluid in a piping component from environmental temperature changes.
2. For cryogenic systems utilizing ball valves, the ball must have an upstream relief hole to prevent over pressurization inside the ball cavity due to thermal expansion.
3. When relief protection is used, the piping system shall be in accordance with ASME B31.3 paragraph 301.4.2 (fluid expansion effects).
  - a. Liquid lock relief valves shall be installed whenever cryogenic liquids can be trapped between closures.
  - b. For all liquids, relief valves shall be installed between closures to prevent over pressurization of the pressure system, except when an analysis indicates the pressure of the trapped liquid will not exceed the MAWP of the components that contain the trapped liquid. A copy of this engineering analysis shall be contained in the pressure system documentation.
  - c. Liquid lock relief valves shall not have a set point greater than 120% of the MAWP.<sup>20</sup>
  - d. Liquid lock relief valves shall be ½" NPS (nominal pipe size) minimum unless code-acceptable documentation in accordance with ASME B31.3 paragraph 300(c)(3) is available to demonstrate a smaller size is acceptable<sup>21</sup> (a 1/16" O.D. tubing length might be able to utilize a smaller relief valve than ½").

---

<sup>20</sup> ASME B31.3 Chapter II, Part 6, paragraph 322.6.3

<sup>21</sup> ASME Section VIII Division 1, Part UG-128, and B31.3 paragraph 322.6.3.

NOTE: The above reference to ½ in. NPS is not be intended to encourage the use of threaded pipe which is NOT recommended for most systems requiring leak tightness, especially hazardous fluid systems.

#### M. Oxygen Systems

1. Design of systems used for oxygen/oxidizer service shall conform to ASTM G 128 and NFPA 55.
2. Selection of components and soft-good materials (e.g., valve gaskets), shall be evaluated for oxygen/oxidizer material compatibility.
3. To mitigate adiabatic compression heating, fast acting valves (e.g., ball valves, solenoid valves) shall not be used as pressurization valves or vent valves.<sup>22</sup>
4. Shall be designed to mitigate human error (i.e., should not rely on operator to open valves in a specific sequence or timeframe). Selection and placement of components must take priority over operator compliance with procedures.
5. Shall be designed to allow for periodic maintenance (e.g., replace components and soft-goods that have oxidized) and shall provide a means for maintaining cleanliness level during maintenance.
6. Design must incorporate means to prevent adiabatic compression that could lead to ignition.
7. If system design cannot be controlled through component selection, operating practices, compatible materials, or when the system cannot be modified to improve its compatibility then shielding, must be placed around the system.
8. Ensure adequate fire suppression devices/systems are strategically located near or around all oxygen/oxidizer systems (see NFPA 45 for guidance in laboratory areas).

#### N. Piping and Tubing

1. Piping or tubing shall be protected with a pressure relieving device. In instances where a pressure relieving device cannot be installed, the piping shall be designed to withstand the highest pressure that can be developed (see Code Case 2211, and ASME Section VIII, Division 1, part UG-140).
2. Wall thinning caused by bending of tubing shall be accounted for when performing MAWP calculations, as defined in ASME B31.3 Chapter II, Paragraph 304.2.

---

<sup>22</sup> ASTM G 88

3. Determination of piping/tubing MAWP, or wall thickness required for a specific internal design pressure, shall be verified prior to selection by performing the following calculation as found in ASME B31.3, paragraph 304 for piping/tubing where  $t < D/6$ :

$$\text{To find wall thickness : } t = \frac{PD}{2(SEW + PY)}$$

$$\text{To find MAWP: } P = \frac{2SEWt}{D - 2tY}$$

Where:

$t$ = pressure design wall thickness of tubing.

$P$ = Internal design pressure

$R$ = Inside radius (Outside radius, minus the wall thickness)

$D$ = Outside diameter of pipe/tubing as measured

$S$ = Stress value for material from ASME B31.3 Table A-1

$E$ = quality factor from ASME B31.3 table A-1A or A-1B

$W$ = Weld joint strength reduction factor per ASME B31.3 paragraph 302.3.5(e).

$Y$ = Coefficient from ASME B31.3 Table 304.1.1

4. The following formula may be used for determination of piping Schedule. Variables are the same as above.

$$\text{Schedule} = \frac{1000P}{S}$$

5. For piping/tubing used in pressure systems designated as “High Pressure Fluid Service” (as defined in B31.3 Chapter IX), wall thickness of piping and tubing shall be determined using ASME B31.3 Chapter IX, Para K304.
6. Unlisted piping/tubing shall meet the requirements of ASME B31.3 Chapter III.
7. Piping/tubing of unknown material specifications shall not be used in pressure systems.
8. Non metallic piping and piping lined with nonmetals shall conform to ASME B31.3 Chapter VII.
9. ASME B31.1 shall be used for steam system piping where the steam, or vapor generated is greater than 15 psig, and high temperature water is generated at pressure exceeding 160 psig, and/or temperatures exceeding 250°F.

10. *Guidance: Use of seam welded pipe or tubing is strongly discouraged.*

**O. Piping Components**

1. Components that meet a listed standard in ASME B31.3 shall be selected for use in construction or fabrication of a piping system. Components that conform to a published specification or standard may be used, provided that a documented review of the specification indicates the component meets the ASME code. Other unlisted components shall be evaluated based upon criteria of ASME B31.1, ASME B31.3, or ASME Section VIII.
2. Pressure systems shall have all major components (flexhoses, valves, pumps, vessels, gages, pressure transducers, flow meters, etc) documented on the attached components list form and shall be maintained in the pressure system documentation package. The following shall be provided as a minimum for all components:
  - a. Manufacturer
  - b. Model Number
  - c. MAWP
  - d. Material (e.g., 316 stainless, brass, etc.)

**P. Unlisted, Specialty, or Unique Components<sup>23</sup>**

1. Components that are not built to the standards listed in the codes -- including those built to other standards, manufacturers' standards, or built by LANL -- shall be qualified by the owner and/or the designer as follows:
  - a. Components built to other published standards, or standards that are not listed in the ASME Code may be used with the following limitations:
    - (1) The pressure design shall meet applicable ASME Code requirements
    - (2) The designer shall be satisfied of comparable code construction.
  - b. Components built to manufacturers standards:<sup>24</sup>
    - (1) The system owner shall obtain and provide documentation (to be maintained in the pressure system documentation package) which support how the materials, design, and fabrication of the component meet the applicable ASME Code requirements.
  - c. Components built at LANL

---

<sup>23</sup> See ASME B31.3, para 302.2.3. Listed components can be found in Table 326.1.

<sup>24</sup> "Proof" discussed at 304.7.2.



- (1) Requires qualification by engineering calculations to support pressure design consistent with the applicable code.
  - (2) Calculations shall be substantiated by one of the following methods:
    - (a) Extensive successful service under the same loading and service conditions
    - (b) Experimental stress analysis<sup>25</sup>
    - (c) Proof test (e.g., Sect VIII UG-101 would be 3X design pressure)
    - (d) Detailed stress analysis (such as finite element method)<sup>26</sup>
2. Documentation of acceptability shall be by calculation. A form is also available to assist in evaluating unlisted components.

**Q. Piping Flanged Joint Connection Assembly**

1. Shall conform with one of the following:
  - a. Manufacturer recommendations based on the joint design and all materials of construction
  - b. ASME PCC-1, "Guideline for Pressure Boundary Bolted Flange Joint Assembly"
  - c. ASME Section VIII Appendix 2, Rules for Bolted Flange Connections with Ring Type Gaskets
  - d. Special calculations by the designer with concurrence by CPSO
  - e. Applicable B31 piping code

**R. Piping Supports and Flexibility Analysis**

1. Follow B31.3 Process Piping for piping supports. *Guidance: A LANL B31.3 Process Piping Guide D20-B31.3-G is also available.*
2. Flexibility analysis of a piping system shall be performed on all systems. The analysis shall conform to the requirements as defined in ASME B31.3, Chapter II paragraph 319.4.2. Exceptions to this requirement are the following, as defined by B31.3 paragraph 319.4.1:
  - a. Those that are duplicates of successfully operating installations
  - b. Those that can be judged adequate by comparison with previously analyzed systems.

---

<sup>25</sup> See ASME Section VIII, Division 2, Annex 5.F.

<sup>26</sup> See evaluation as described in ASME Section VIII, Division 2, Part 5.

- c. Systems of uniform size that have no more than two anchor points, no intermediate restraints, and fall within the limitation of the equation found in ASME B31.3 paragraph 319.4.1.
3. Tubing that is anchored to beams of dissimilar material properties, in temperature varying environments (i.e. stainless steel tubing braced to a carbon steel I-beam on the exterior of a building) shall incorporate flexibility, which is induced by thermal expansion/contraction.
4. Additional requirements for anchoring are in ESM Chapter 5 Structural (e.g., ASCE 7) and Master [Specifications](#) 13 4800 Sound, Vibration, and Seismic Control and 22 0529 Hangers and Supports for Plumbing Piping and Equipment.

#### S. Pressure and Vacuum Gauges

1. Overpressure relief protection shall be provided on bourdon-tube, dial-indicating pressure gauges that operate at pressures greater than 15 psig by one of the following means:
  - a. Pressure gauges approved by Underwriters Laboratories (UL) in accordance with UL-404, "Standard for Gauges, Indicating Pressure, for Compressed Gas Service" Standard for Safety is acceptable.
  - b. Tempered safety glass or plastic face or shield meeting the requirements of ANSI Z97.1, and a blowout back or plug for pressure relief.
2. Pressure gauges that serve primarily a pressure indication for over pressure protection (i.e., not used for process data collection) shall have a range of at least 1.25 times, but no more than twice the set pressure of the relief device as recommended in ASME Section VIII, Div. 1, Appendix M, Para. M-14.
3. MAWP shall be known. This value is typically greater than the dial indicator range.

#### T. Pressure Relief Requirements

1. Pressure vessels and piping shall have protection against over-pressurization.
2. Maximum inlet piping pressure drop shall be in accordance with ASME Section VIII, Div 1, part M-6, and Div II, Section 9.
3. The nominal pipe size of piping, valves and fittings, and vessel components between a pressure vessel and its safety, safety relief, or pilot operated pressure relief valve shall be at least as large as the nominal size of the device inlet.
4. For the above, the cumulative total of all non-recoverable inlet pressure losses shall not exceed 3% of the valve set pressure, as based on the valve nameplate capacity, corrected for the fluid characteristics.

5. Discharge lines from pressure relief devices shall be in accordance with ASME Section VIII, Div 1 Parts M-7 through M-12, and Div II Parts 9.A.4 through 9.A.5.
  - a. The design characteristics of the discharge system shall be designed as such to accommodate the requirements of ASME Section VIII Div 1 Part UG-125.<sup>27</sup>
  - b. If unable to vent to a captured vent vessel, relief devices that vent flammable and/or toxic fluids shall vent to the building exterior and away from ignition sources as defined in NFPA 30 and 45.
  - c. Discharge lines shall be run as direct as practicable.
6. Pressure relief devices shall have calculations as defined by AP-341-605. A copy of the calculations shall be maintained in the pressure system documentation package. Calculations shall define required flow capacity to prevent system pressure from exceeding 110% (or 116%, 120%, or 121% when allowed by ASME Section VIII, Division 1 part UG-125) of the MAWP of the component it is protecting during maximum fault conditions (see Exclusions section).
7. A full verification record is not required for relief devices installed, and designed by the original manufacturer of a pressure system. However, if the manufacturer or system owner cannot supply documentation justifying the design of the pressure relief system, then calculations must be generated to ensure safe design.
8. Pressure relief devices for vessels that are to operate completely filled with liquid shall be designed for liquid service, unless the vessel is otherwise protected against overpressure.
9. Pressure relief devices need not be installed directly on vessels, or components they are protecting, provided the following is met:
  - a. There are no flow control, or shut off valves between the component being protected and the relief device,
  - b. The relief device is suitable for the fluid service, meeting the capacity requirements for the application, and
  - c. Design ensures that the pressure of the vessel or component the valve is protecting does not exceed the MAWP at operating conditions, except as permitted in Section VIII Div 1.
10. In cases where the required use of pressure relief devices is not practical, pressure control methods may be used only by approval from the CPSO.

---

<sup>27</sup> See ASME B&PVC Section I and IV for boiler-specific capacities.

11. Pressure relief devices shall be tested and tagged with the “Test” tag as described in this document prior to being installed into any pressure system, which includes but is not limited to: set pressure, test date, and due date as described by this document.
12. Pressure relief designs shall include a calculation report that includes at least, but not limited to (for rupture disks adjust as appropriate) the following:
  - a. Manufacturer
  - b. Model number (M/N)
  - c. Inlet size and type
  - d. Outlet size and type
  - e. Set/burst pressure (psig)
  - f. Service fluid
  - g. Relieving capacity
  - h. Relieving capacity at overpressure percent<sup>28</sup>
  - i. Orifice trim (Not applicable to rupture disks)
  - j. ASME Code Section
  - k. Blow down (if critical, not required for rupture disks)
  - l. Determination of pressure relief device sizing
  - m. Determination of required relieving flow
  - n. Determination of inlet/outlet pressure drop at relieving conditions.
13. Pressure relief devices installed into a pressure system that protect ASME BPVC Section I, IV, VIII, or X equipment shall be an ASME UV or UD stamped relief device as defined in Section VIII, Division 1 Part UG-125(a).
14. A pressure relief device’s set point shall not exceed the MAWP of the system, except where allowed by the applicable ASME code (e.g., liquid lock and fire sizing).
15. A pressure relief device shall have sufficient flow capacity such that system pressure does not exceed 110% of the system MAWP (or 116% as defined by ASME Section VIII Div 1 Part UG-125 for multiple relief devices), at full open source pressure.

---

<sup>28</sup> Allowable percentage as defined by ASME Section VIII, Division 1 Parts UG-125 through UG-136, or ASME Section I and IV.

16. Relief device fire sizing calculations are required for relief devices that are used when a vessel and/or piping meet the definition as found in ASME Section VIII, Division 1 Part UG-125 (c)(3), which states: “Pressure relief devices intended primarily for protection against exposure of a pressure vessel to fire or other unexpected sources of external heat installed on vessels having no permanent supply connection and used for storage at ambient temperature of non-refrigerated liquefied compressed gases.”
17. Flow capacity of pressure relief devices that are intended primarily for protection against exposure of a pressure vessel to fire or other unexpected sources of external heat, that are installed on vessels having no permanent supply pressure connection (or can be isolated from pressure relief) and used for storage at ambient temperatures of non-refrigerated liquefied compressed gases, shall not exceed 120% of the stamped set pressure of the valve, or the MAWP.<sup>29</sup>
18. Power boilers: Relief systems shall be designed using the calculations found in B31.1 Appendix II.
19. Flow Tests: Where this is the only accurate method for determining relief system capacity, flow tests of relief systems shall be performed as defined in ASME PTC-25 and API 521<sup>30</sup>. The objective of the test is to ensure that system pressure will not exceed over pressure percentage as defined in ASME Section VIII, Division 1 Part UG-125<sup>31</sup> (typically 110% above the MAWP), when allowed/approved by CPSO.<sup>32</sup>
  - a. For systems with multiple relief valves, liquid lock relief valves, and fire protection valves, refer to ASME Section VIII Div 1, Parts UG-125 through UG-136 for further guidance:
    - i. Relief devices shall be tested in-place, installed in their designated systems, without modification to plumbing arrangement.
    - ii. The pressure measurement device that measures the pressure downstream of the flow-limiting device shall be calibrated.

---

<sup>29</sup> ASME Section VIII, Division 1 Part UG-125 (c)(3)(a). See API 521 for calculations.

<sup>30</sup> In-house certification of relief system to verify flow capacity of system, not for UV stamping of relief valves (LANL does not manufacture relief valves or hold a UV stamp). FOD PSO considered authorized observer under LANL jurisdiction.

<sup>31</sup> See also ASME B&PVC Section I and IV for boiler specific applications

<sup>32</sup> ASME Section VIII Div 1, UG-131 requires flow checks to validate capacity of relief valves. Method used to validate relief system flow characteristics and performance to ensure UG-125 percentages are maintained/ achieved when piping and fittings are installed on relief valve ports.

Testing shall comply with NBIC/NB-23 Part 2, section 2.5.7, and ASME PTC-25 Part II, Section 4, part 4.3 “In-service Testing Procedures”. Capacity compliance shall be based on ASME Section VIII, Division 1 Part UG-125

- iii. Shall be tested with the maximum supply (source pressure) pressure at full open flow (i.e. pressure regulator increased to maximum) while observing pressure readings.
  - iv. If it appears, as the pressure is gradually increased as the relief valve is flowing, that the pressure in the system will exceed 110% of the MAWP of the system, the test shall be stopped immediately. The valve is undersized, or the pressure relief tubing is causing too much flow restriction. The relief system design has failed the test and needs to be redesigned.
    - a) System shall not be allowed to operate until provisions have been made to accommodate for required relief capacity as defined by ASME Section VIII, Division 1 Part UG-125.
  - v. If the relief valve maintains the system pressure below 110% of the MAWP, (at maximum flow of the pressure regulator) of the system, then the relief system is designed and sized appropriately.
- b. Relief device flow tests shall be documented and witnessed by FOD PSO.
- c. The following information shall be obtained after the flow check with the pressure system documentation:
- i. The source supply pressure
  - ii. Manufacturers model number and serial number of the relief device
  - iii. Set pressure of the relief device
  - iv. Gauge calibration tracking number and due date.
  - v. Maximum pressure obtained during the flow check
  - vi. Indication of design/sizing failure to maintain pressure below 110% MAWP (or as specified by ASME Section VIII, Division 1, part UG-125)
  - vii. Pressure measurement device calibration tracking number, and due date
  - viii. Any special provisions shall be stated in the flow test documentation (i.e. installation of an upstream orifice at the pressure source to minimize flow rate.)
20. The use of stop valves is not allowed for heating boiler applications, and is discouraged for other applications, but may be used when all the following requirements are met:<sup>33</sup>
- a. The increase in pressure drop from the stop valve does not reduce the relieving capacity of the vent system below what is required
  - b. The stop valve shall be locked in the open position during system operation. For a stop valve to be satisfactorily locked in the open position it shall have a physical means to inhibit unplanned operation of the valve. The lock shall be key-operated.

---

<sup>33</sup> See ASME Section VIII Div 1 Part UG-135(d), and B31.3 paragraph 322.6.1

- c. Closing of the stop valve requires the system to be safe with strict procedural controls in place to warn personnel of the possible hazards.
- d. If the above cannot be met, but a stop valve is required for operations, documented approval/variance must be obtained through the CPSO.

**U. Restraints for flexible hoses, tubing, and relief device discharge tubing.**

1. Relief device discharge lines, flexible tubing, and vent lines shall be evaluated for reaction thrust considerations, and shall be sufficiently braced to withstand the maximum and sustained thrust potential.<sup>34</sup>
2. Approved alternatives (of those shown below) or restraining devices approved by a designer may be used if the restraining device withstands the thrust challenge posed by both the initial surge thrust and the sustained surge thrust.
3. Flexible tubing and hoses over 12 inches in length and in service pressure greater than 150 psig shall be constrained at both ends or shielded in case of end-connector failure. The maximum separation distance between flexible hose restraints shall not exceed 6-ft intervals. (e.g., an 8-ft. flexhose must use 3 restraints).

---

<sup>34</sup> ASME Section VIII, Division 1 Part UG-22, and Appendix M (M-12). ASME B31.3 Paras. 301.5.5, 319.5, and 322.6.2.

4. Safety grips (e.g., Kellums® grips or Adel® clamps #MS-21919DG shown below) connected from hose to hose, hose to structure, or from hose to other components shall be used and shall be capable of restraining the hose or end fittings in the event of joint separation unless an adequate alternative for personnel protection is provided. Example shown below:<sup>35</sup>

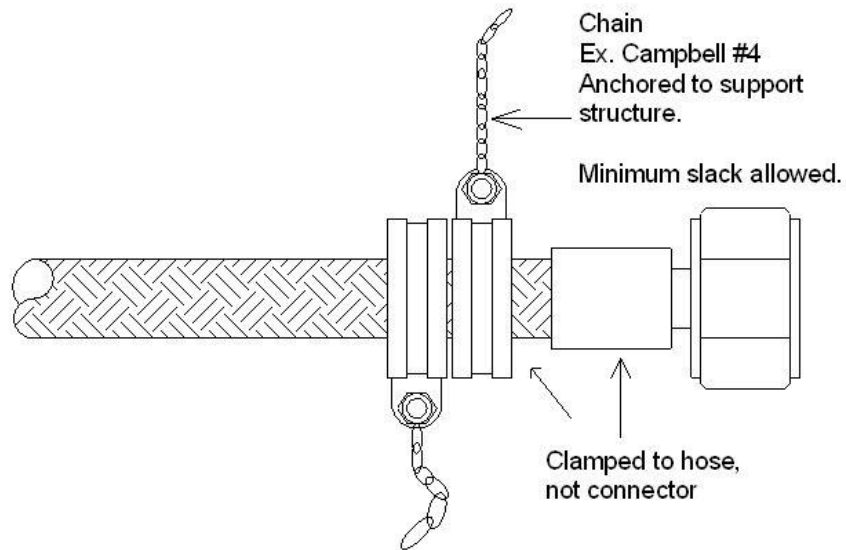

<sup>35</sup> Flexible element restraints concepts throughout this section: WSTF WSI-SW-0024.B (NASA White Sands Test Facility Standard Instruction)



5. Flexible tubing/hoses enclosed inside equipment or test setups that do not expose personnel to injury when pressurized are excluded from being secured.
6. Specifically excluded are free-rotating/translating systems whose designs prohibit securing at 6-ft intervals.

#### V. Pressure Vessel Requirements

1. Pressure vessels shall either have calculations as defined by AP-341-605 or manufacturers data report (i.e., U-1 or U-1A report).
2. Pressure vessels, in a pressure system, that fall under the scope of ASME Section VIII, shall be ASME stamped, NBIC registered, and copies of the manufacturer's data reports (U-1A forms), shall be provided as part of the procurement package. A copy of these documents shall be maintained in the pressure system documentation package.
3. Pressure vessels with a design pressure less than 10,000 psig shall be designed, and fabricated according to ASME BPVC Section VIII, Divisions 1, and 2, where Division 2 focuses on design by analysis.
4. Pressure vessels with a design pressure exceeding 10,000 psig shall be designed, and fabricated in accordance with ASME BPVC Section VIII, Division 3.
5. Vessels that, by design limitations, cannot be ASME-code-stamped shall be proven equivalent as code stamped using the most applicable ASME B&PV code(s) for design, inspection, and testing. All requirements of the applicable code(s) shall be documented and maintained in the pressure system documentation package, and must be approved by the CPSO.
6. Vessels, other than ASME-stamped vessels or DOT vessels, used within their intended service shall have documentation justifying their use. Requirements in ASME Section VIII or other applicable code for this specific type of construction shall be followed and verified. Documentation shall include, but is not limited to:
  - a. Material
  - b. Material condition
  - c. Thickness of major pieces
  - d. Corrosion allowance
  - e. Weld qualification
  - f. Calculations, to include flanges, manholes, nozzles, etc
  - g. Loading listed in ASME Section VIII, Div 1 Part UG-22

7. DOT or mobile pressure systems shall be retested per 49 CFR or ASME Section XII.
  - a. Refilling of an expired DOT portable vessel is prohibited
  - b. Expired DOT vessels which still contain the contents may be used until the contents are gone, provided that no pressure source is connected to the vessel. Removal of contents shall be by gravity or vapor pressure only.
  - c. If the vessel is to be used as a permanent installation and not maintained in accordance with 49CFR, the vessel must be reviewed according to ASME Section VIII, and the DOT stamp must be obliterated.
8. Vendor Assembled or Manufactured Pressure Systems (those types of components or systems that are considered to be non-excluded as defined by this document).
  - a. Procurement specifications for new pressure systems or vessels, or modifications to existing pressure systems must be submitted to the CPSO for review and evaluation before the procurement action or the modification.
  - b. Manufacturer's supplied data shall be stored in the pressure system documentation package.
  - c. The designer shall review and define the contents of the pressure system documentation package specifically for the vendor supplied pressure system/vessel.
  - d. When a component of a vendor supplied pressure system is serviced or changed from the original delivered configuration that item shall be processed per this chapter.
9. Fiber-Reinforced Pressure Vessels (ASME Section X)
  - a. Fiber-reinforced plastic pressure vessels in a pressure system shall be ASME-stamped (RP stamp) and NBIC-registered, and copies of the manufacturer's data reports (e.g., RP-1, RP-2, Q106, Q107, etc.) shall be maintained in the system documentation package.

#### W. System Interactions

1. Where two or more dissimilar pressure systems tie into each other, and/or are fed by a single pressure supply, they must be reviewed to determine the need for installation of check valves. The following scenarios should be determined:
  - a. Use of double block and bleed may fail due to human error
  - b. Where two dissimilar systems must be continuously pressurized from a single pressure source.
  - c. Systems can be potentially over pressurized by the other.

- d. System contents may back flow into the other and cause contamination or over pressurization.
  - e. System contents migration into the source pressure supply, which can potentially contaminate all other systems that connect to the same source.
2. Double check valves in series shall be installed on pressure systems to mitigate system fluid migrations and interactions where two or more incompatible fluid systems are pressurized by the same pressure source (e.g., monomethyl hydrazine and dinitrogen tetroxide systems pressurized by the same helium source). See example below:

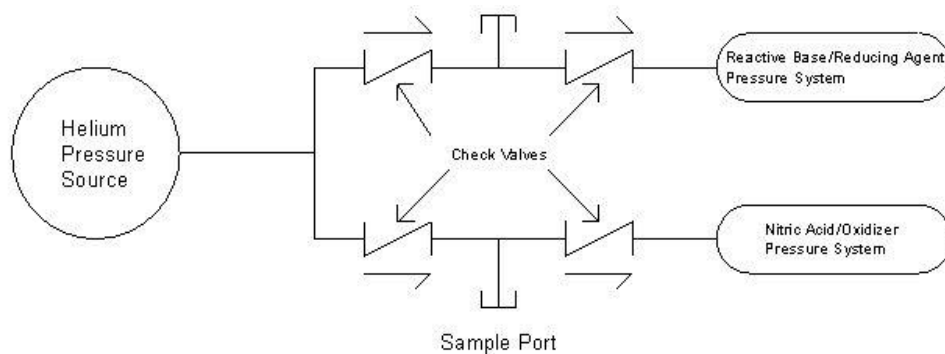

**X. Vacuum and Externally pressurized components and piping**

- 1. Vacuum Vessels
  - a. Vacuum vessel design shall be designed in accordance with ASME Section VIII. For example: See ASME Section VIII Division 1 parts UG-28 and UG-29.
  - b. Vacuum vessels and vacuum systems that have a source pressure or purge gas that exceeds 15 psig shall be designed, fabricated, and tested according to ASME Code Section VIII, and B31.3.
- 2. Vessels, Piping and Tubing
  - a. Vacuum piping, and externally pressurized piping or vessels shall be designed in accordance with ASME B31.3 Chapter II, Para 304.1.3 which references ASME Section VIII, 1 Div 1 parts UG-28 thru UG-30 (vessels under external pressure).<sup>36</sup>

<sup>36</sup> ASME B31.3 has specific requirements for variables, “L” and “S” as defined in Section VIII, Div 1.

**Y. Vent Systems**

1. All pressure systems shall be designed with a means to manually vent pressure from the system.
2. Breaking loose fittings to vent pressure is absolutely prohibited. Vent systems must be supplied with means of controlled venting through a valve.
3. Except for captured vent systems (for lethal or toxic systems) vents shall not be plugged.<sup>37</sup>
4. Vent ports should be covered with metallic screens or other type of device to inhibit exhaust ports being blocked by environmental phenomenon (e.g., insect nests). Screens/covers shall not inhibit the flow capacity of the vent valve.
5. Relief devices that are in an environment which could cause the exhaust ports to be plugged (e.g., insect nests) shall be fitted with a metallic screen or other device to keep them from becoming plugged. Screens/covers shall not inhibit the flow capacity of the relief device.

**Z. Welding Design**

1. Design shall address the following criteria (e.g., weld design calculations, drawings) as defined by the applicable code of construction and ESM Chapter 13:
  - a. Weld procedure specifications (WPS)
  - b. List of welding materials, to include filler materials
  - c. Heat treatment requirements
  - d. Method of welding, brazing or soldering (e.g., GTAW, SMAW, oxyacetylene, etc)
  - e. Cleaning methods
  - f. Contain engineering design calculations or other approved ASME method that establishes the structural integrity of the design.
  - g. Specify the method(s) to examine the weld as defined by the appropriate ASME code (e.g., Section VIII, Div 1 or B31.3)
  - h. Specify the pass/fail criteria to apply to the method(s) used to examine the weld.
  - i. Detail joint geometry, weld type, size, material type, and specification.
  - j. Utilize welding symbols in accordance with AWS A2.4 “Standard Symbols for Welding, Brazing, and Nondestructive Examination.

---

<sup>37</sup> In case venting is required in an emergency

- k. See also ESM Chapter 13 Welding Fabrication Procedure 2-01, ASME B31 Series Piping Codes.

## 11.0 Procurement, Fabrication, and Assembly

### A. General

1. LANL Master Specification 43 4113, "Gas and Liquid Pressure Vessels," shall be used for design/build procurements of pressure vessels. This specification is applicable both to new acquisitions and to modification or repair work to existing pressure vessels (with issuance of rev. 0 of this Section I, spec required review for conformance).
2. Vessels shall be code-fabricated and code-stamped; however, if required design features prevent code compliance, then follow the Non-Code Vessels section below.
3. Including all other references to procurement requirements in this document, all procured pressure systems and components shall cite the following where applicable, and shall be received with documentation from the manufacturer or vendor showing proof of compliance. Documentation shall be maintained in the pressure system documentation package.
  - a. Applicable ASME Code Inspection and testing documentation
  - b. Cleanliness level oxygen/oxidizer components shall be 175A or cleaner as specified in this document and ASTM G93
  - c. Welding specification, including inspection, and testing, where applicable.
  - d. Operating conditions
  - e. Loadings (snow, wind, seismic, etc) as found in ESM Chapter 5 shall be included.

### B. Rental Pressure Systems

1. Rental pressure systems shall be maintained in accordance with the applicable laws and national consensus codes and standards by the vendor owner.<sup>38</sup> Documentation shall be made available upon request.
2. Rental pressure systems shall be verified maintained by the owner.

### C. ASME Code-Stamped Vessels

1. Procure from a manufacturer holding an ASME Code stamp as defined by the applicable ASME B&PVC Section, and have vessel stamped accordingly.

---

<sup>38</sup> Captured by LANL ASM [Form](#) 410 (3041.00.0410) Goods and Services Requiring Internal Review and Approval.

2. A copy of the manufacturer's data reports (e.g., U-1A, U-2, etc) shall be supplied with the vessel, and shall be maintained in the pressure system documentation package.
3. The ASME Code design calculations shall be obtained as part of the procurement, but may be completed by others (e.g., LANS or an Architect/Engineer)
4. Receipt inspection of fabricated vessels shall include verification of manufacturer's data reports (e.g., U-1 form), and visual identification of "U" stamp.

**D. Non-Code Vessels**

1. Procurements of non-code stamped vessels must be reviewed by CPSO.<sup>39</sup>
  - a. Vessel MAWP and over pressure protection is sufficient to achieve code equivalent protection from over pressurization.
  - b. Design, and inspection documentation is readily available (weld inspection, pressure tests, etc).
  - c. Have calculations and documentation generated indicating the minimum wall thickness requirements to justify the MAWP.
2. For on-site fabrication, calculations (weld, MAWP, wall thickness, etc) shall also be submitted to the CPSO prior to fabrication.

**E. Flexible Hoses and Flexible Tubing Procurement**

1. Flexible hoses shall not be procured without end connectors attached by the manufacturer.
2. Flexible hoses shall be procured from the manufacturer with the MAWP stamped, or etched, or tagged on the hose or end connectors indicating the maximum allowable working pressure of the assembly.
3. Flexible hoses shall not be assembled or repaired, except by manufacturer.

**F. Tagging and Labeling**

1. Tag/label all piping and components as shown on the system schematic.
2. Follow ESM Chapter 1, Section 200.

---

<sup>39</sup> Captured by LANL ASM [Form 410](#) (3041.00.0410) Goods and Services Requiring Internal Review and Approval.

**G. Welding, Brazing and Soldering**

1. Welding, brazing or soldering on pressure systems, piping, and components, that are within the scope of this program shall comply with the applicable ASME BPV or B31 codes. Proof of ASME compliance shall be accomplished by documenting the following:
  - a. Welder qualifications as defined by the applicable code and ESM Chapter 13.
  - b. Welding procedure specifications (WPS) as defined by the applicable code and ESM Chapter 13.
  - c. Inspection, examination, and testing, (e.g. radiography, dye penetrant, or pressure qualification test) as defined by the applicable code of construction, to include other requirements defined in ESM Chapter 13.
2. Welding procedures and personnel shall be certified for the application that they are performing through the LANL welding program, as defined by ESM Chapter 13.
3. Fabrication shops that do not possess an ASME “U” authorization, regardless of individual personal training, qualifications, and certifications, shall not be considered equivalent to Code-certified shops and hence shall only perform non-Code welding.
4. Welding on pressure systems or components shall be inspected as mandated in the applicable ASME BPV or B31 codes by a certified inspector as defined in ESM Chapter 13.
5. Welding/brazing qualifications shall conform to the ASME Section IX, “Welding and Brazing Qualifications,” and the requirements of ESM Chapter 13.
6. On-site welding shall be performed by welders that are currently certified, having completed testing and qualification in accordance with ESM Chapter 13, GWS 1-05, “Welder Performance Qualification/Certification.”
7. When welded joints (i.e. orbital, butt welding) are used, all welds shall have examination records as required by “Inspection, Examination, and Testing” Chapter VI of ASME B31.3 or ASME B31.1 as appropriate, and shall be traceable by one of the two following methods:
  - a. A weld number referenced on the system drawing or sketch and pertinent information for each weld (weld map).
  - b. A stamp traceable to the welder along with examination records.
8. Welding inspection, examination, and testing records shall be maintained in the pressure system documentation package.

**H. Piping and Tubing**

1. Bending of tubing/piping shall be performed such that there is no wrinkling, stretching, or ovaling of the tubing. Use of tubing mandrels for thin walled tubing is mandatory.

2. Sand, beads, or other abrasive material shall not be used to accomplish uniform bends for pressure system tubing/piping.
3. Tubing that is anchored to beams of dissimilar material properties in temperature varying environments (e.g., stainless steel tubing braced to a carbon steel I-beam on the exterior of a building) shall have the flexibility needed for thermal expansion/contraction.
4. Use of tube cutting wheels is discouraged (but not prohibited) for stainless steel tubing. The preferred method is use of a hacksaw and tubing vice with a hacksaw guide.
5. Tubing shall be prepped by interior and exterior reaming prior to fitting makeup. The end face of the tubing shall be flat as possible and without sharp edges after reaming.
6. For Swagelok installations, follow LANL Master Spec [Sections](#) 40 0511 and 40 0527.

#### I. **Cleaning**

1. Components, piping and tubing specified for oxygen or oxidizer service shall be cleaned as specified in this document, prior to assembly, and shall be assembled in a manner that maintains cleanliness.
2. Pressure systems shall be considered for cleanliness requirements. All components shall be cleaned to an acceptable level which removes contaminants that could lead to system failure or contamination.

#### J. **Alignment**<sup>40</sup>

1. Twisting or distortion of piping or components, to bring into alignment, which introduces strain in the equipment, is strictly prohibited.
2. Alignment of faces of flanged joint assemblies, before bolt up, shall be aligned as defined in B31.3, paragraph 335.
3. Flange bolt holes shall be aligned within a maximum offset as defined in B31.3 paragraph 335.
4. Prior to assembling any joints to be cold sprung, supports and anchors shall be examined to ensure that required movement is allowed by the supports, and that undesired movement is controlled.

---

<sup>40</sup> ASME B31.3 Para 335 Assembly and Erection, unless noted otherwise.



**K. Flanged joint assemblies:<sup>41</sup>**

1. Flanges shall be replaced whenever any damage has been caused to the sealing surface that prevents the gasket from sealing. Excessive torque beyond torque specifications to achieve a leak free seal is strictly prohibited.
2. Torque up of flange bolts shall be that which is defined by calculation or as determined by industry torque-table values, and shall be defined in assembly instructions.
3. Bolted flanges shall be re-torqued no less than 24 hours after initial torque following assembly, and prior to any leak checks or pressure verification tests.<sup>42</sup>
4. Nuts shall have full thread engagement on the bolts or studs. One to two exposed threads is the preferable amount that defines full thread engagement. The minimum acceptable engagement is the outer edge of the nut being not less than flush with the end of the bolt or stud.<sup>43</sup>

**L. Threaded Joints**

1. Threaded fittings shall be lubricated with lubricant that is compatible with the system fluid (e.g., halocarbon, hydrocarbon, fluorocarbon, etc) prior to assembly to prevent galling and friction welding.

**M. Tubing Joints**

1. Flareless and compression tubing joints shall be assembled per the manufacturer's instructions. Where the manufacturer specifies a specific number of turns for the nut, these shall be counted from the point at which the nut becomes finger tight.
2. For Swagelok installations, follow LANL Master Spec [Sections](#) 40 0511 and 40 0527.
3. Flared tubing shall be visually inspected for surface pits, and splits prior to assembly. Use of a "Go, No-Go" gauge for flare sizing is highly recommended.
4. Flared tubing with imperfections in the flare must be rejected.

---

<sup>41</sup> ASME B31.3 Para 335 Assembly and Erection, unless noted otherwise.

<sup>42</sup> Accommodate material relaxation. General industry good practice.

<sup>43</sup> LANL ASME B31.3 Process Piping Guide

N. **Oxygen and Oxidizing media components cleanliness requirements** <sup>44</sup>

1. General requirements

- a. This section is applicable to both liquid oxygen (LOX) and gaseous oxygen (GOX) systems and other similar oxidizing agents (e.g. N<sub>2</sub>O<sub>4</sub>, HNO<sub>3</sub>, etc.)
- b. Components installed into oxygen or oxidizer fluid systems shall be cleaned to a level equal to or better than 175A as defined in ASTM G93 para. 11.4.3, where the nonvolatile residue remaining after cleaning is less than 1 mg/ft<sup>2</sup>, and the particulate count is less than the following where “X” is the size of the particles counted:

Number of Particles Allowed	Size Range (µm/100 mL)*
0	X > 175
1	100 < X < 175
5	50 ≤ X < 175
20	X < 50
5	Fibers
<p><i>*100 mL refers to the amount of solvent fluid (e.g. de-ionized water, isopropyl alcohol, HFE 7100, etc) that is used to flow through, or around the components (or tubing and fittings) to collect the particulate and non-volatile residue (or total carbon) samples described in ASTM G93.</i></p>	

- i. Oxygen/oxidizer pressure systems must be disassembled for cleaning. Each component must be cleaned prior to assembly. Non-volatile cleaning agents may remain in trapped spaces, which could react with oxygen. Cleaning solutions may degrade non metals in an assembly. Caustic and acid cleaning solutions may cause crevice corrosion in assemblies.
- ii. Any method of cleaning may be utilized provided that cleaning method meets, or exceeds the requirements as defined in ASTM G93 for level 175A. <sup>45</sup> Components may be cleaned by the manufacturer.
- iii. Components must be maintained clean during the assembly/construction process.

<sup>44</sup> ASTM G 93

<sup>45</sup> Refer to ASTM A 380 which describes cleaning, descaling, and passivation of stainless steel parts, equipment and systems.

- iv. Oxygen-compatible lubricants should be selected after component cleaning
  - v. Components cleaned for oxygen service shall not be left in the open, unprotected. Care should be taken to avoid contamination of particulate and oil deposits on surfaces that will be in direct oxygen service.
  - vi. Components cleaned for oxygen service shall be handled with clean gloves or handling devices to maintain oil-free cleanliness of component.
2. Cleaning procedures
- a. The cleaning method used shall incorporate three cleaning steps as defined in ASTM G93 as follows:
    - i. Precleaning – removal of gross contaminants
    - ii. Intermediate cleaning – use of alkaline salts, detergents, acids, or caustics to remove solvent residues and residual contaminants.
    - iii. Final cleaning- removal of minute contaminants, in a clean room environment. Includes drying/purging and packaging to protect components from re-contamination.
  - b. Cleanliness verification shall be documented and maintained in the pressure system documentation package.
3. Packaging
- a. All packaging used to for cleaned components shall be as clean as, or cleaner than the clean level specified for the component. Packaging shall be clearly marked in accordance with ASTM G93 para 12.2, “Package Marking.”
  - b. Cleaned components that are not bagged/wrapped shall be plugged/capped with plugs/caps that are as clean or cleaner than 175A.
4. Assembly
- a. Where applicable, all components cleaned for oxygen service shall be handled with clean, lint free gloves to prevent contamination to the fluid surfaces of the component.
  - b. Components shall be maintained clean to the maximum extent possible during the assembly process.
  - c. Care shall be taken to minimize the potential for contamination
  - d. Only use of oxygen compatible grease is authorized for thread lubrication. A listing of tested materials is available in ASTM G63.

- e. PTFE tape is authorized for NPT fittings cleaned for oxygen service. Ensure that the tape is applied so that it does not extend into the flow path<sup>46</sup>.
- f. Ensure all tubing has been pre-fabricated, properly de-burred and cleaned prior to assembly.
- g. Ensure all weld slag has been removed from interior of lines.
- h. After assembly and before wetting the system with oxygen, purge the system using clean, dry gaseous nitrogen to remove assembly generated contaminants through the system or to a benign location.

## 12.0 Inspection, Testing, and Maintenance

### A. Inspection/Examination

NOTE: It is the responsibility of the designer, the manufacturer, the fabricator, and the erector as applicable, to prepare the records as required for inspections and testing, that are defined by the most applicable ASME code<sup>47</sup>.

1. Pressure systems shall be examined as defined by the applicable ASME code prior to service.
2. Examination activities to verify the quality of the work shall be performed by persons other than those who performed the activity being examined. Such persons shall not report directly to the immediate supervisors responsible for the work being examined.
3. The designer of a pressure system or component shall define the examination requirements to meet or exceed those required by the applicable ASME code. Examination documents shall be maintained in the pressure system documentation package. Examination methods shall be specified in the engineering design, and shall define type, extent and acceptance requirements for the following methods, as instructed by the ASME Code:
  - a. Visual inspection
  - b. Magnetic particle examination
  - c. Liquid penetrant examination
  - d. Radiographic examination
  - e. Ultrasonic examination
  - f. In-process weld examination

---

<sup>46</sup> ASTM G93

<sup>47</sup> Example: ASME B31.3 Paragraph 346.

4. The designer shall identify the minimum requirements of examination as defined by the code.
5. The manufacturer, fabricator or builder shall perform examinations as required by the design documents and applicable code.
6. The fabrication, repair, or alteration documentation shall have evidence of the examination; evidence shall be maintained in the pressure system documentation package.
7. Where in-process weld examinations are substituted for RT or UT as allowed by ASME B31.3 paragraph 341.4.3(3)(c), the in-process examination shall be documented with the appropriate information as required by ASME B31.3, paragraph 344.5 and this documentation shall be maintained with the pressure system documentation package.

#### B. Testing

NOTE: The following testing criteria references B31.3 requirements. The most applicable B31 code requirements in the event of conflict.<sup>48</sup>

1. Pressure systems shall be tested prior to service as defined in the applicable ASME code.
2. Facility pressure systems shall be tested as defined in LANL Master Specification 22 0813.
3. Programmatic piping systems shall undergo an initial leak check, and initial pressure qualification test as defined in B31.3 Chapter VI, paragraph 345 (Testing) prior to being placed in service (or as defined in B31.1 Chapter VI). Test may be either pneumatic or hydrostatic, and shall conform to the following:
  - a. A written procedure shall be generated to instruct the test. Tests shall be recorded and maintained in the pressure system documentation package.
  - b. The pressure of the leak test shall be gradually increased in no less than three graduations, checking for leaks between each graduation.
  - c. All joints, including welds and bonds, are to be left un-insulated, and exposed for examination during leak testing (pressure qualification test).
  - d. Pneumatic pressure qualification tests shall be conducted from a remote location with positive control of personnel access. After the test is completed, the system pressure shall be reduced to MAWP, at which time personnel may then access the system.
  - e. Pressure relief device shall be provided, having a set pressure not higher than the test pressure plus 50 psig, or 10% of the test pressure, whichever is less.

---

<sup>48</sup> B31.3-based requirements are presented because the majority of LANL piping systems fall within the scope of B31.3 where defined in B31.3, paragraph 300.1.1

- f. Test pressure for the pressure qualification test of pressure systems shall not be less than 150% the design pressure for hydrostatic tests, and 110% for pneumatic tests as defined in ASME B31.3 Para's 345.4 and 345.5. For refrigerant systems, the pneumatic pressure shall not be less than 110%, and shall not exceed 130% of the design pressure as defined in ASME B31.5, Para. 538.4.2.
- g. Hydrostatic tests shall be performed with water. If water is not suitable (could freeze, or cause adverse affects to piping or process), another suitable non-toxic liquid may be used.
- h. Test instrumentation used to meet the requirements of this document and codes shall be calibrated.
- i. The pressure of the qualification test shall be maintained for at least 10 minutes.
- j. Qualification tests shall be witnessed by a LANL Certified Inspector meeting the qualifications of the applicable code. *Contact ADPMGT's Construction Engineering Group for assistance.*
- k. Test procedures and results shall be maintained in the system documentation package.

**C. Fluid Service Categories, Inspection, and Inspection/Testing Intervals.**

1. FS Categories are LANL fluid categories, not ASME Code categories. FS categories are for determination of inspection interval, and are not intended to provide design guidance (e.g., an FS1 pressure system does not necessarily need to be designed and built for ASME Category M fluid service, unless of course, the FS1 system contains fluids that meet the ASME definition of Category M).
2. Where consensus cannot be accomplished, the CPSO shall make the final determination of fluid service category.

3. The following Fluid Service (FS) categories determine the inspection (Certified/Authorized Inspector) intervals for pressure vessels and piping.<sup>49</sup>

Required Inspection	Maximum period between inspection (years)	
	FS1 or FS2	FS3
External Visual	3	5
Internal Visual or volumetric (e.g., ultrasonic thickness or radiography)	5	10

- a. Boilers: Exception to the FS inspection intervals are boilers. Boilers shall be inspected according to New Mexico Administrative Code (NMAC) [14.9.4.25](#), “Inspection Methods and Frequency.” A certificate inspection may be issued with an external inspection; however, an internal inspection must be made within six months of the external inspection.<sup>50</sup>
- i. When the construction does not permit an internal inspection, one external inspection annually is required.
  - ii. Annual internal inspection is required for high-pressure boilers and high pressure steam generators.
  - iii. Every 24 months an external and internal inspection shall be performed on the following:
    - a) Direct fire steam jacketed kettles
    - b) Low-pressure steam boilers
    - c) Low-pressure hot water heating boilers

<sup>49</sup> Based on API 570, “Piping Inspection Code”, Table 6-1, and is also used by Savannah River Site for vessel inspection intervals.

<sup>50</sup> At the date of release of this document, LANL is not considered exempt from this state regulation.

4. The following table indicates test (set point verification) and replacement intervals of pressure relief devices.

Fluid Service/Type	Test Frequency	Reuse or Replace Device	Test or Inspect Reused Devices
Non-corrosive gas and liquids (including LN2, kerosene, oils, etc.)	3 years	Reuse or replace	Test
Corrosive Service; Water	2 year	Reuse or Replace	Clean and Test
LP Gas; Propane; Refrigerant valves (e.g., Henry, Superior)	5 years	Reuse or Replace	Test
Steam (ASME BPV Section 1)	Yearly	Reuse or Replace	Test
Steam (ASME Sec VIII)	2 years	Reuse or replace	Test
Steam Pilot Relief Valve	2 years	Reuse or Replace	Complete disassembly and Test
Domestic Water Heater	5 years	Replace	N/A
Oxygen	2 years	Reuse or replace	Test/Clean
Rupture Disk: Flat/Forward Buckling and Bent/Breaking pins in non-plugging and non-lethal service	N/A	Replace as required	Inspect or replace
Rupture Disk: Flat/Forward Buckling (Plugging or Lethal Service) or Reverse Buckling	2 Years	Replace	N/A
<p>NOTES:</p> <p>ALL RELIEF DEVICES SHALL BE REPLACED OR REBUILT EVERY 10 YEARS; exception to this requirement is inert gas fluid service valves, which may be retested.</p> <p><i>Basis for table is EMRef-57 (EMRef is a Standards Program system for maintaining references/bases)</i></p>			

5. Testing of pressure relief valve set points can be performed with the valve installed in the system or by bench test. The FOD PSO must be present for in-place set point verifications, and flow tests. In-place testing must be performed using a FOD PSO approved procedure<sup>51</sup>.

<sup>51</sup> See ASME PTC-25 for relief device testing requirements.



6. Any relief valve that has been modified, (e.g. spring replacement, orifice exchange, welding, etc.) except for set point adjustments, must be flow tested to verify capacity and operation. Flow tests shall be documented and maintained in the pressure system documentation package.<sup>52</sup>
7. Regardless if the relief valve is ASME Code stamped (UV), or not, where in-place set-point testing of relief valves is the preferred method of testing, the system shall be provided with a traceable calibrated gage. Tolerance on set-point verifications shall be +/- 2 psi for a set pressure less than 70 psi. For set points greater than 70 psi, the tolerance shall be +/- 3% of the stamped set point as defined by ASME BPV Section VIII, Div 1, part UG-126(d).
  - a. ASME (UV) stamped valves requiring disassembly to change the set point (i.e. spring replacement) shall be performed by an organization accredited by the National Board, holding a "VR" stamp, to disassemble the valve and change the set point.
  - b. ASME (UV) stamped valves that do not require disassembly to adjust the set-point, to the stamped set point indication, do not require an organization holding a VR stamp to make the adjustment.
  - c. Adjustments of set point pressure on relief valves (regardless of UV stamp) shall be performed by a LANL approved, and designated relief device testing facility.
8. All tested valves (regardless of UV stamp) shall have, affixed by the testing organization, a "Test Only" tag as described by NBIC Part 3, Section 5.9.4 with a minimum of the following information:
  - a. Test report number (unique identification number)
  - b. Name of testing organization, LANL test shop identification, or in-place flow procedure document number.
  - c. MAWP
  - d. Set pressure
  - e. Date of test
  - f. Due date of next test (as defined in this document)

---

<sup>52</sup> See ASME Section VIII, Division 1, Part UG-131.

9. *Guidance: A typical model work order for PRV testing would be:*

Task	Title
04	PS-MAINT TO ERECT/REMOVE SCAFFOLD TO REPLACE PRV
03	PS-PURCHASE NEW OR BENCH TEST RELIEF VALVE LANL PSS#403 (CWS-PRV-5) PER PMI (TBD)
02	PS-PERFORM POST MOD TESTING
01	PS-REMOVE/REPLACE RELIEF VALVE PSS#403 (CWS-PRV-5) PER PMI (TBD)

10. *Guidance: LANL preventative maintenance procedures (PMIs) [adopted from former Site Support Subcontractor (KSL)] including several relating to pressure safety are available from the following website (use IE browser): <http://intranet:8080/Procedures.aspx>. At time of issue they included:*

- [40-25-039 Boiler Relief Valve Testing](#)
- [40-25-040 Pressurized Tank Relief Valve Testing](#)
- [40-25-041 Pressurized Vessel Relief Valve Testing](#)
- [67-00-038 Testing of Relief Devices \(UGAS\)](#)
- [76-35-010 Boiler Safety Relief Valve Inspection](#)
- [76-35-012 Safety Relief Valve Lever Test](#)

11. All pressure relief (regardless of ASME Code stamp) valves that are removed from the system and sent to either a VR holder or CPSO-authorized testing organization shall be tested using the following fluid media as defined by NBIC/NB-23 Part 2 (2.5.7):

Fluid System	Fluid medium used to test valve
High pressure boilers	Steam
High temperature hot-water boilers	Steam
Low pressure steam heating boilers	Steam
Programmatic and process steam service	Steam*
All other valves marked for steam service	Steam
Hot water heating boiler	Air or water
Hot water heater temperature and pressure relief valves	Air or water (replacement is preferred)
Air and gas service	Air or Nitrogen
Liquid service	Water

\*air is suitable provided the manufacturers steam to air correction factor is used

**D. Corrosion and Remaining Life**

1. Corrosion Analysis shall be maintained in the pressure system documentation package for those systems containing fluids of corrosive characteristics.
2. Remaining life shall be calculated as follows:<sup>53</sup>

Where:

$t_{actual}$  = The actual minimum thickness determined at the time of inspection

$t_{initial}$  = Initial thickness (long-term corrosion rate) or thickness measured in a previous inspection (short-term corrosion rate)

$t_{reqd}$  = the required minimum thickness

<sup>53</sup> API 570 “Piping Inspection Code”, Section 7 and NBIC Part-2, section 4.4.7.2

time= time between thickness measurements

$$\text{Remaining life} = \frac{(t_{\text{actual}} - t_{\text{reqd}})}{\text{Corrosion Rate}}$$

$$\text{Corrosion Rate} = \frac{t_{\text{initial}} - t_{\text{actual}}}{\text{time}}$$

#### E. PassPort Database (CMMS)

1. Relief devices and non-excluded vessels shall be entered and tracked using the PassPort maintenance tracking database, and shall be maintained current and accurate. The following data is required:
  - a. The following data fields are required to be entered for all pressure protection items:
    - i. Pressure system identification/inventory database number.
    - ii. Location
    - iii. Component/Subcomponent I.D. number string (CLI number)
    - iv. Component/subcomponent description
    - v. Component/subcomponent Status
    - vi. Relief Valve Calculation Number
    - vii. Working Fluid
    - viii. FOD PSO Z# and Name
    - ix. Fluid Service (FS) code
    - x. Manufacturer (and model number)
    - xi. Maximum Temperature (°F)
    - xii. MAWP at maximum temperature (psig)
    - xiii. Next inspection/test due date.
    - xiv. Inspection/Test frequency

- b. Additional data for pressure vessels
  - i. National Board number
  - ii. Maintenance Program Code (“P” for pressure vessels, “R” for relief devices)
  - iii. Type of inspection or Model Work Order (UT, RT, etc)
  - iv. Code required minimum wall for shell and heads (TBD)
- c. Additional data for pressure relief devices
  - i. Set or nominal burst pressure
  - ii. Inlet size and type
  - iii. Orifice size (TBD)
  - iv. Capacity (TBD)
  - v. Maintenance program code (V for Valve/Disk)

**F. DMAPS Database**

1. Vessel inspection data shall be entered into the DMAPS Database program. *Contact QA-PM Group for assistance.*
2. A copy of the vessel inspection report produced by DMAPS shall be provided to the pressure vessel owner.
3. Vessel inspection reports shall be maintained in the pressure system documentation package.

**G. Repairs or Alterations (Welding)**

1. Repairs and alterations that require welding to code stamped vessels (“U”, “U2”, etc) shall be performed as instructed per the applicable ASME Boiler and Pressure Vessel Section, and shall be performed by an institution holding an “R” stamp.
2. ASME PCC-2 shall be used as a guide for repair of pressure equipment and piping.
3. Repairs to Piping, and piping components shall be performed as defined in ASME B31.1 or ASME B31.3
4. Repairs to pressure relief, or pressure safety valves displaying the “UV” stamp, shall be performed by an institution holding a “VR” stamp
5. Repairs and modifications to pressure vessels and piping shall be verified through engineering calculations prior to performing the operation.

6. Completion of Repairs and alterations shall be verified by inspection and testing as defined by the applicable ASME BPV or B31 code, and NBIC/NB23, Part 3, Section 4. Inspectors Forms (R-1, R-2, etc) shall be maintained in the pressure systems documentation package.
7. Repairs and alterations made to ASME Section III stamped nuclear facility components (e.g., “NV”, “NB”) shall be performed by an institution holding the “NR” stamp.

### 13.0 DOT, IM, and UM Portable Tanks

#### A. Special Instructions for DOT-4L Cylinders<sup>54</sup>

WARNING: A cylinder used for CO<sub>2</sub> service must remain CO<sub>2</sub> service, and must not be used for other gas products, especially oxygen or nitrous oxide.

1. Follow the manufacturer’s instructions for service and maintenance
2. Excessive loss of product or excessive build-up of pressure is an indication of possible loss of vacuum in the vacuum jacket. Follow the manufacturer’s instructions for troubleshooting.
3. If frost spots appear in a non uniform manner, or are in miscellaneous areas the cylinder may have internal damage and will need to be removed from service until repaired (call cylinder manufacturer for details.)
4. Relief devices shall be maintained as defined in this document
5. Where manufacturer recommends checking the set point of relief devices in place, the method shall be performed as defined in this document.
6. Solidified contents in cylinders (CO<sub>2</sub>) shall be re-liquefied per the manufacturer’s instructions.

#### B. Inspection Frequencies

1. Records of DOT, IM, and UM vessel inspection and certification reports shall be made available upon request.
2. Owners of DOT, IM, and UM vessels shall maintain their DOT vessels certified within the inspection interval frequency.
3. DOT, IM, or UM vessels that are not permanently installed in a pressure system shall comply with the retest frequency as described in CFR Title 49, Chapter 1, Part 173, Subpart B Section 173.34, “Qualification, Maintenance and Use of Cylinders.” The following table displays the inspection frequencies, and retest pressure for cylinders.

---

<sup>54</sup> Chart Industries, Inc., “Liquid Cylinder” Users Manual P/N 10642912 Date:12/00

Specification under which cylinder was made	Minimum retest pressure (psig)	Retest period (years)
DOT-3	3000 psig	5
DOT-3A, 3AA	5/3 times service pressure, except non-corrosive service *	5, 10, or 12 *
DOT-3AL	5/3 times service pressure	5 or 12 *
DOT-3AX, 3AAX	5/3 times service pressure	5
3B, 3BN	2 times service pressure	5 or 10 *
3C	Retest not required	Retest not required
3D	5/3 times service pressure	5
3E	Retest Not Required	Retest not required
3HT	5/3 times service pressure	3 *
3T	5/3 times service pressure	5
4	700 psig	10
4A	5/3 Times service pressure *	5 or 10 *
4AA480	2 times service pressure	5 or 10 *
4B, 4BA, 4BW, 4B-240ET	2 times service pressure except non-corrosive*	5, 10, or 12 *
4C	Retest not required	Retest not required
4D, 4DA, 4DS	2 times service pressure	5
DOT-4E	2 times service pressure except non-corrosive*	5
4L	Retest not required	Retest not required
8, 8AL	-	10 or 20*
DOT-9	400 psig (maximum 600)	5
25	500 psig	5
26 (for filling over 450 psig)	5/3 times service pressure	5
26 (for filling at 450 psig)	2 times service pressure	5
33	800 psig	5
38	500 psig	5
Special Permit Cylinder	See current special permit.	See current special permit
Foreign Cylinder (see CFR 49 section 173.301(j) for restrictions on use).	As marked on the cylinder, but not less than 5/3 of any service or working pressure marking.	5
*See CFR Title 49 Section 173.34(e) for specific instructions for types of vessels.		

4. The following table displays the NBIC inspection frequencies for DOT, IM, and UM portable tanks/ vessels. Portable vessels shall be maintained within their inspection due dates.<sup>55</sup>

Specification	Periodic Inspection and Test	Intermediate Periodic Inspection and Test
UM or UN Portable Tanks once placed in service	5 years	2-1/2 years
DOT 51 Portable Tanks	5 years	-
DOT 56 or DOT 57 Portable Tanks (The first periodic inspection and test is required 4 years after being placed into service and each 2-1/2 years thereafter.)	2-1/2 years	-
DOT 60 Portable Tanks (the first periodic inspection and test is required 4 years after being placed into service and the per the schedule to the right	For the first 12 years of service, every 2 years.	After 12 years of service, yearly.
Retesting is not required on a rubber lined tank, except before relining.		
For IM and UN Portable Tanks, periodic inspection and test shall include at least an internal and external of the portable tank and fittings, taking into account the hazardous material intended to be transported.		

## 14.0 Mobile Pressure Systems and Transport Tanks

### A. Definitions

1. LANL owned mobile pressure systems and transport tanks, (to include Category 406; 4 psi) are subject to the requirements of this document which are included within the scope of ASME Section XII. These systems and vessels include, but are not limited, to the following:
2. Portable tanks for transporting cryogenic fluids (greater than 120 Gallons), not part of a Road-Tank vehicle.
3. Rail Tanks
4. Cargo Tanks – Intended primarily for the carriage of liquids or gases and includes appurtenances, reinforcements, fittings, and closures. Is permanently attached to or forms a part of a motor vehicle, or is not permanently attached to a motor vehicle but which by reason of its size, construction, or attachment to a motor vehicle is loaded or unloaded without being

<sup>55</sup> NBIC Part-2 Table S6.14, Inspection Intervals



removed from the motor vehicle. Is not fabricated under a specification for cylinders, portable tanks, tank cars, or multi-unit tank car tanks.

5. Pressure vessel designs within the scope of Section XII are as follows:
  - a. Full vacuum to 3000 psig
  - b. Temperature range is between -452°F to 650°F
  - c. Thickness of shells and heads does not exceed 1.5 inches.

**B. Procurement**

1. Transport tanks shall be procured with the ASME (T) stamp symbol.
2. Mobile pressure systems and transport tanks that do not bear the ASME stamp symbol shall be evaluated as equivalent through engineering calculations.

**C. Pressure Relief Devices**

1. Shall comply with the tolerances and capacities as defined by ASME Section VIII, and shall be installed as defined in ASME Section XII, paragraph TR-130
2. Shall be tracked in the PassPort data base as defined by this document
3. Shall be code stamped relief devices (TV) or (TD). ASME Section VIII stamped components are authorized to be used on (T) stamped vessels provided the requirements of Section XII are met as defined in ASME Section XII, Article TG-120.2.
4. Shall comply with the re-test/replace intervals, as specified in this document.

**D. Piping, Valves, and Fittings**

1. Each connection shall be clearly labeled to indicate its function
2. Piping, valves and fittings shall be grouped and protected from damage.
3. Shall comply with ASME B31.3 as defined by ASME Section XII

**E. Pressure System Documentation Package**

1. The manufacturer's data report (T-1A, B, or C) and/or partial data report shall be maintained in the pressure system documentation package.
2. Relief valve calculations, recall date, and set pressure shall be documented and maintained in the pressure system documentation package.

3. Repairs and alterations shall be documented and maintained in the pressure system documentation package.
4. Records of inspections shall be maintained in the pressure system documentation package as defined in ASME Section XII, Article TP-6.

**F. Repairs and Alterations**

1. Shall be performed by an institution holding the (TR) stamp.
2. Repairs and alterations shall be performed in accordance with NBIC/NB-23
3. Shall be performed as defined in ASME Section XII Part TP

**G. Tests and Inspections**

1. Testing and Inspection shall be performed as defined in ASME Section XII, Articles TP-4, and TP-5.

**15.0 Pressure System Documentation Package Contents**

A. **Required documentation table (to be maintained in pressure system documentation package).**

**Table 17-1**

<b>Documentation Package Item</b>	<b>Required When</b>	<b>Owner Verification</b>	<b>FOD PSO Verification</b>
1. Pressure System Certification Status Form	Every Package		
2. List of pressure system Contents (argon, helium, kerosene, etc.)	Every Package (Where information is considered classified, list location of documentation)		
3. Forms in this document	Every Package		
4. Spreadsheet listing all pressurized components, indicating: MAWP, soft goods, and material of construction.	Every Package		
5. System drawings	Every Package		
6. Waiver/Variance (If applicable)	If the system or any item of the system has an applicable waiver to the requirements of this document		
7. CPSO MAWP de-rating documentation	The system has a pressure vessel that does not have a formal, documented inspection by certified inspector.		
8. Materials list for piping and fittings to include MAWP, diameters, wall thickness, and material type of all fittings; and code of construction, published specification or standard, or other justification (e.g. engineering calculations)	Every Package		

Documentation Package Item	Required When	Owner Verification	FOD PSO Verification
9. Vessel Fabrication Documentation	The pressure system contains ASME code-stamped boilers or pressure vessels (which includes boilers, pressure vessels, heat exchangers, and accumulators) Provided by manufacturer per ASME Section VIII Div 1 part UG-120(a)(3)(a).		
a. Manufacturers' data report (e.g., U-1A)	If package contains boilers, pressure vessels, heat exchangers, or accumulators		
b. Modification Instructions/Procedures	Modifications are done to any boiler, pressure vessel, heat exchanger, or accumulator by LANL		
c. Weld examination forms in accordance with ESM Chapter 13, as defined by applicable ASME Code.	Welding is performed on any boiler, pressure vessel, heat exchanger, piping, or accumulator.		
d. Non-Destructive Evaluation (NDE) data reports	NDE is performed on any boiler, pressure vessel, heat exchanger, or accumulator		
e. Special Calculations such as for welds, and wall thickness	Performed for any non-code stamped pressure vessel, heat exchanger, or accumulator		
f. Vendor Drawings	Any boiler, pressure vessel, heat exchanger, or accumulator purchased or used.		
g. Vessel modification reports	Modifications performed on any boiler, pressure vessel, heat exchanger, or accumulators		
h. DOT Vessel Information	The pressure system contains a DOT Vessel		
i. ASME MAWP derating calculations	DOT Vessel is permanently installed in a pressure system without being removed for re-certification.		
j. Pressure Qualification Test Procedures and data	A DOT vessel is permanently installed the pressure system.		
k. DOT Fabrication Drawing or Vendor Drawing	A DOT vessel is in the pressure system package		
l. DOT inspection/recertification documentation	A DOT vessel is in the pressure system, but not permanently installed, and is owned by the pressure system owner (no intention of returning vessel back to a vendor)		

Documentation Package Item	Required When	Owner Verification	FOD PSO Verification
10. Non-ASME code Fabricated Vessel Information (code-equivalent Documentation)	The pressure system contains Non-ASME-code stamped boilers and pressure vessels (which includes boilers, pressure vessels, heat exchangers, and accumulators)		
a. ASME code equivalent documentation for systems with pressure vessels which includes but is not limited to minimum wall thickness determination, corrosion allowance, weld efficiency rating, support structure loading, nozzle calculations. Calculations will use the material values specified in the ASME code.	A non code boiler, pressure vessel, heat exchanger and accumulator is in the pressure system package		
b. Pressure Qualification Test Procedures and data	Non code boilers, pressure vessels, heat exchangers and accumulators is in the pressure system package		
c. Modification procedures/instructions	Modifications were made to non code boilers, pressure vessels, heat exchangers and accumulators is in the pressure system package		
d. Non-Destructive Evaluation (NDE) data reports	NDE was done to non code boilers, pressure vessels, heat exchangers and accumulators is in the pressure system package		
e. Weld examination forms as described in ESM Chapter 13.	Welding was done to non code boilers, pressure vessels, heat exchangers and accumulators is in the pressure system package		
f. Special Calculations such as welding	Special calculations are performed for non code boilers, pressure vessels, heat exchangers and accumulators is in the pressure system package		
g. Vendor Drawings	Piece parts are used to fabricate non code boilers, pressure vessels, heat exchangers and accumulators is in the pressure system package		
h. Vessel modification reports	Vessel is modified by other than LANL personnel		
11. Pressure Safety Devices	The pressure system contains a pressure safety device (which includes but is not limited to relief valves and rupture discs)		
a. Flow Test documentation as described in this Chapter	Whenever a relief valve has been modified, or when calculations cannot be generated.		
b. Safety Relief Calculations for relief valves, in accordance with ASME requirements	Every Package, unless calculations cannot be generated, a flow test is required in place of calculations.		

Documentation Package Item	Required When	Owner Verification	FOD PSO Verification
c. Pressure Relief Calculations for Rupture Disks in accordance with ASME requirements	Rupture Disks are in the pressure system		
d. Thermal Load Calculations (Fire Sizing)	A relief device is used to protect against thermal induced over pressure.		
e. Certified Test Data of relief valves, e.g. steam Pressure safety valves are certified by NBIC coded shop	A PRD is modified or tested by an outside facility		
f. Documentation of relief valve modification	If a relief valve has been modified		
g. Identification as a liquid lock PRD on PRV Recall Summary Sheet and pressure system Component List spread sheet.	PRD's are used as protection against liquid lock overpressure.		
12. Piping System Documentation	The system contains pipe, tube, or other components not classed as boilers or vessels.		
a. Fabrication Documentation	Code equivalent systems must have records of all fabrication, inspection, test, and design data required by the applicable code.		
b. Pressure Qualification Test Procedures and data as defined by the applicable piping code	A pressure system package contains piping system components		
c. Modification procedures/instructions	Components of a system were modified from original construction		
d. Non-Destructive Evaluation (NDE) data reports	NDE is performed on piping system components		
e. Special Calculations such as Welds and Orifices	A pressure system package contains piping system components that have been welded, modified with "home-made" orifices, or unlisted components.		
f. Corrosion allowance calculations per ASME B31G	Piping is used in corrosive fluid service		
g. Code required calculations e.g. flexibility analysis, pipe supports, wind loading, and seismic loading. see specific code for additional detail. (e.g. B31.3 paragraph 319 and 321)	A pressure system package contains piping system components		

Documentation Package Item	Required When	Owner Verification	FOD PSO Verification
h. Weld examination forms in accordance with ESM Chapter 13, and special required examinations defined in the applicable code.	Welding of pipe or tube in a pressure system package was performed		
i. Weld In-Process Forms in accordance with ESM Chapter 13, and the most applicable code.	When in-process examination of welding is used		
j. Vendor Drawings or sketches	A pressure system package contains vendor supplied systems, piping, or components		
13. Flex-hose external visual inspection records (see attached forms)	The system contains flexible hoses		
14. Pump or compressor discharge pressure curves, calculation, or table	The pressure system contains pumps or compressors		
15. Oxygen System Hazard Analysis	Pressure system is an oxygen system		

## Appendix A

### 10CFR851 Appendix A, Part 4 Pressure Safety

(a) Contractors must establish safety policies and procedures to ensure that pressure systems are designed, fabricated, tested, inspected, maintained, repaired, and operated by trained and qualified personnel in accordance with applicable and sound engineering principles.

(b) Contractors must ensure that all pressure vessels, boilers, air receivers, and supporting piping systems conform to:

(1) The applicable American Society of Mechanical Engineers (ASME) Boiler and Pressure Vessel Code (2004); sections I through section XII including applicable Code Cases (incorporated by reference, see § 851.27)

(2) The applicable ASME B31 (Code for Pressure Piping) standards as indicated below; and or as indicated in paragraph (b)(3) of this section:

(i) B31.1—2001—Power Piping, and B31.1a—2002—Addenda to ASME B31.1—2001 (incorporated by reference, see § 851.27);

(ii) B31.2—1968—Fuel Gas Piping (incorporated by reference, see § 851.27);

(iii) B31.3—2002—Process Piping (incorporated by reference, see § 851.27);

(iv) B31.4—2002—Pipeline Transportation Systems for Liquid Hydrocarbons and Other Liquids (incorporated by reference, see § 851.27);

(v) B31.5—2001—Refrigeration Piping and Heat Transfer Components, and B31.5a—2004, Addenda to ASME B31.5—2001 (incorporated by reference, see § 851.27);

(vi) B31.8—2003—Gas Transmission and Distribution Piping Systems (incorporated by reference, see § 851.27);

(vii) B31.8S—2001—Managing System Integrity of Gas Pipelines (incorporated by reference, see § 851.27);

(viii) B31.9—1996—Building Services Piping (incorporated by reference, see § 851.27);

(ix) B31.11—2002—Slurry Transportation Piping Systems (incorporated by reference, see § 851.27); and

(x) B31G—1991—Manual for Determining Remaining Strength of Corroded Pipelines (incorporated by reference, see § 851.27).

(3) The strictest applicable state and local codes.

(c) When national consensus codes are not applicable (because of pressure range, vessel geometry, use of special materials, etc.), contractors must implement measures to provide equivalent protection and ensure a level of safety greater than or equal to the level of protection afforded by the ASME or applicable state or local code. Measures must include the following:

(1) Design drawings, sketches, and calculations must be reviewed and approved by a qualified independent design professional (i.e., professional engineer). Documented organizational peer review is acceptable.

(2) Qualified personnel must be used to perform examinations and inspections of materials, in-process fabrications, nondestructive tests, and acceptance test.

(3) Documentation, traceability, and accountability must be maintained for each pressure vessel or system, including descriptions of design, pressure conditions, testing, inspection, operation, repair, and maintenance.



## **Appendix B**

### **ASME Codes, Standards, and LANL CENG References**

#### A. Boiler and Pressure Vessel Sections

Section I – Rules for Construction of Power Boilers

Section II Materials, Part A – Ferrous Material Specifications

Section II Materials, Part B – Nonferrous Material Specifications

Section II Materials, Part C – Specifications for Welding Rods, Electrodes, and Filler Metals

Section II Materials, Part D – Properties (Customary and Metric)

Section III – Rules for Construction of Nuclear Facility Components NCA General Requirements for Division 1 and 2.

Section III, Division 1 – Rules for Construction of Nuclear Facility Components

Section III, Division 2 – Rules for construction of Nuclear Facility Components (Code for concrete containments)

Section III, Division 3 – Rules for Construction of Nuclear Facility Components (containments for transportation and storage of spent nuclear fuel and high level radioactive material and waste)

Section IV – Rules for Construction of Heating Boilers

Section V – Nondestructive Examination

Section VI - Recommended rules for the care and operation of heating Boilers

Section VII – Recommended guidelines for the care of power boilers

Section VIII, Division 1 – Rules for construction of pressure vessels

Section VIII Division 2 – Alternative rules for construction of pressure vessels

Section VIII, Division 3 – Alternative rules for construction of high pressure vessels (10,000 psig or greater)

Section IX – Qualification standard for welding and brazing procedures, welders, brazers, and welding and brazing operators

Section X – Fiber-reinforced plastic pressure vessels

Section XI – Rules for in-service inspection of nuclear power plant components

Section XII - Rules for construction and continued service of transport tanks

B. B31 Piping Codes

B31.1 – Power Piping

B31.2 – Fuel Gas Piping

B31.3 – Process Piping

B31.4 – Pipeline Transportation Systems for Liquid Hydrocarbons and other liquids.

B31.5 – Refrigeration Piping and Heat Transfer Components

B31.8 – Gas Transmission and Distribution Piping Systems

B31.8S – Managing System Integrity of Gas Pipelines

B31.9 - Building Services Piping

B31.11 – Slurry Transportation Piping Systems

B31.12 – Hydrogen Piping (issuance pending)<sup>56</sup>

B31G – Manual for determining the remaining Strength of Corroded Pipelines.

B31Q – Pipeline Personnel Qualification

---

<sup>56</sup> As of the date of release of this document, ASME B31.12 (Hydrogen Piping and Pipelines Code) had not been published. Although not invoked by 10 CFR 851 (2008) it is expected that B31.12 may be applicable to hydrogen processes at LANL and, when released, is expected to be evaluated for use in the design, repair, modification, inspection, and testing of hydrogen systems in the same way that the other codes listed above are required. Until release of B31.12, the most applicable piping code is B31.3.

C. Other ASME standards relevant to pressure systems and inspection

ASME A13.1 – Scheme for the identification of piping systems

ASME B16.5 – Piping Flanges/Fittings

ASME B36.10M – Welded and Seamless Wrought Steel Pipe

ASME B36.19M – Stainless Steel Pipe

ASME CSD-1 – Controls and Safety devices for automatically fired boilers

- ASME HPS – High Pressure Systems
- ASME PCC-1 – Guidelines for pressure boundary bolted flange joint assembly
- ASME PTC-1 – Performance Test Codes
- ASME PTC 25 – Performance Test Code – Pressure Relief Devices
- ASME PTCPM – Performance monitoring guidelines for steam power plants
- ASME PVHO-1 – Safety Standard for pressure vessels for human occupancy.
- ASME QAI-1 – Qualifications for Authorized Inspection (Authorized Inspection Agencies)
- ASME Y14-38 – Abbreviations and Acronyms for Use on Drawings and Related Documents
- D. API (American Petroleum Institute) Referenced Documents
  - API 521 – Pressure-relieving and Depressuring Systems
  - API 579 – Fitness for Service
- E. ASTM Referenced Documents
  - ASTM A 380 – Standard Practice for Cleaning, Descaling, and Passivation of Stainless Steel Parts, Equipment, and Systems
  - ASTM G 93 – Standard Practice for Cleaning Methods and Cleanliness Levels for Material and Equipment Used in Oxygen-Enriched Environments
  - ASTM G 63 – Standard Guide for Evaluating Nonmetallic Materials for Oxygen Service
  - ASTM G88 – Guide for Designing Systems for Oxygen Service
  - ASTM G128 – Guide for Control of Hazards and Risks in Oxygen Enriched Systems
- F. LANL Conduct of Engineering Documents
  - Documents, Administrative Procedures, and Records website:  
<http://int.lanl.gov/orgs/ceng/APs.shtml>
  - LANL Engineering Standards: <http://engstandards.lanl.gov/>

FM01

LANL Pressure System Certification Status Form

(Place this form in pressure system documentation package when completed)

System ID No.: \_\_\_\_\_ Excluded System? \_\_\_\_\_ (Y/N)

Other system Identification name (or number): \_\_\_\_\_

System Location (TA/BLDG/Room) : \_\_\_\_\_ ( not applicable if mobile)

Mobile System "T" number : \_\_\_\_\_ ( not applicable if not mobile)

System Contents: (Nitrogen, Argon, etc) \_\_\_\_\_ (Do not list if classified)

System Fluid Category (FS1, FS2, or FS3): \_\_\_\_\_

Applicable ASME B&PVC Section for System: \_\_\_\_\_ Applicable B31 Code for system: \_\_\_\_\_

System Owner: \_\_\_\_\_ Phone: \_\_\_\_\_

Last Recertification (M/D/YY): \_\_\_\_\_

Next Recertification (M/D/YY): \_\_\_\_\_

Reviewer Name: \_\_\_\_\_

CODE NON-COMPLIANCES (DETAIL BELOW)

Code Non-compliance – A violation of a national consensus code

Example: Pressure relief missing from system.

MINOR NON-COMPLIANCES (DETAIL BELOW)

Minor Non-Compliance – A LANL self-imposed requirement that is not a violation of a national consensus code.

Example: Component I.D. tags missing from system.

Approval Signature List

System Owner \_\_\_\_\_

FOD PSO Initial Review \_\_\_\_\_

FOD PSO Certification \_\_\_\_\_

CPSO Certification \_\_\_\_\_

Sample

**FM02**

**PRV RECALL SUMMARY SHEET**

SYSTEM NAME AND I.D. NUMBER:

PRESSURE RELIEF DEVICE COMPONENT NUMBER	MANUFACTURER	MODEL NUMBER	MAWP (PSIG)	SET PRESSURE (PSIG)	TEST DATE	DUE DATE	PRV TEST LAB REPORT #	FLOW CHECK PROCEDURE or CALCULATION #

Page \_\_\_ of \_\_\_

FOD PSO Certification:

Date:

**FM03**

**Code Non-Compliance Log<sup>5758</sup>**

System I.D. No.:			
System Description:			
Page: _____ of _____			
Description	Code Requirement (section, chapter, paragraph)	Closure & Rationale	Closure Date and LANL PSO Signature

<sup>57</sup> Non-code examples are: undersized relief device, wrong set pressure on relief device, weld repairs without “R” stamp, component MAWP less than system design pressure, un-supported piping, unknown materials used in construction, unknown design pressure, failure to perform and document code required inspections and testing, etc.

<sup>58</sup> All code non-compliances shall be entered into LIMTS, regardless of Management Level.

**FM04**

**Minor Non-Compliance Log<sup>5960</sup>**

System I.D. No.:				
System Description:				
Page: _____ of _____				
Description	Requirement (LANL Document, Section, Paragraph)	Closure/Rationale	Closure Date and Initials	
			System Owner	FOD PSO

<sup>59</sup> Examples of minor non-compliances are: Relief device past recall due date, in-service inspections past due date , chipped paint, lack of flex-hose restraints, leaking fittings, surface anomalies, identification tags, schematics do not match physical layout, mud dauber nests in relief valve discharge ports

<sup>60</sup> For ML-1 or ML-2 initiate NCR



**FM05**

**Flexible Pressure Element Visual External Examination**

Page \_\_\_\_ of \_\_\_\_

System I.D. Number: \_\_\_\_\_

Date of Inspection: \_\_\_\_\_

FOD PSO Signature: \_\_\_\_\_

Component Number	MAWP (if missing, flexhose is unacceptable)	Integrity		Are Flex-Hose restraints used?	Flex-Hose Restraint	
		ACC (good condition, no visible flaws)	UNACC (kinks, frayed, crushed, etc)	Yes/No	ACC	UNACC

**FM06  
Tubing and Piping Data Sheet<sup>61</sup>**

Pressure System Identification number:		Reviewer:		Drawing number:			Date:
Components that tubing section is located between (e.g. MV-4 and PI-3)  ( N/A if all tubing is same size and type throughout the entire pressure system)	Tubing Material  (SS, Cu, CS, etc)	Tubing Spec/Grade Specification  (316-A26, 304L-A358, etc)	Annealed? (yes/no)	O.D. (in.)	I.D. (in.)	Seamless? (yes/no)	Maximum system operating temperature (Fahrenheit)

<sup>61</sup> This data sheet accomplishes the requirements found in ASME B31.3 Paragraph 323.1.3

FM07

Pressure System Component List <sup>62</sup>						
Pressure system documentation package I.D. number:						
System location (TA-BLDG-Room):						
Component I.D.	Manufacturer	Model Number	Material (316 S.S., Brass, etc)	MAWP	Soft good material(s) <sup>1</sup>	Code Stamp (U, UV, etc) <sup>2</sup>

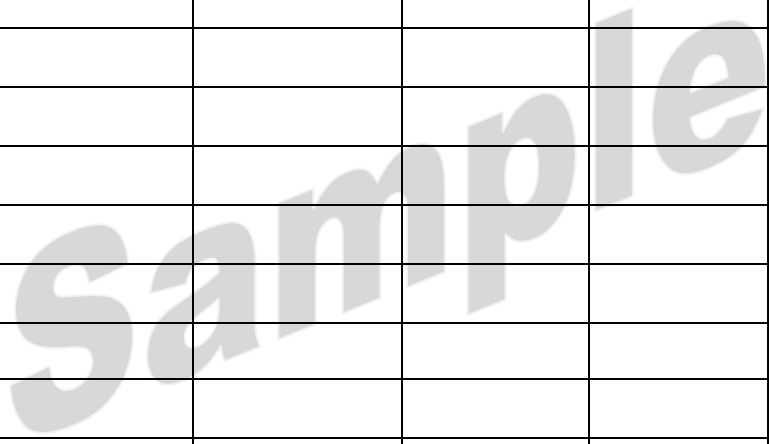

<sup>1</sup> Unknown is an acceptable answer for inert systems, where material compatibility is not an issue.

<sup>2</sup> N/A (Not applicable) is an acceptable answer if component is not code stamped

<sup>62</sup> This form accomplishes configuration control requirements, allows for quick viewing of system piping component characteristics and to ensure adequate pressure relief has been provided. Components found on this form shall be found on the system drawing, and vice-versa.

**FM08  
Pressure Relief Valve Placement Verification Record<sup>63</sup>**

This form is to be maintained in the pressure system documentation package.

1) Perform system review. Identify placement of all components in the pressure system in relationship to a pressure relief device. Can any components be isolated from a pressure relief device? (i.e. can a valve be closed which blocks flow path to a relief device?)

Yes \_\_\_ No \_\_\_

List below, all the components that can be isolated from a pressure relief device. (attach sheets as necessary)

- a) \_\_\_\_\_ b) \_\_\_\_\_ c) \_\_\_\_\_ d) \_\_\_\_\_  
 e) \_\_\_\_\_ f) \_\_\_\_\_ g) \_\_\_\_\_ h) \_\_\_\_\_

2) Is the MAWP, of any of the above identified components, less than the system source supply pressure?

Yes \_\_\_ No \_\_\_

If yes, list components below, and re-design system to provide over pressure protection for the listed components.

Component I.D.	Manufacturer	Model	MAWP (psig)

FOD PSO signature \_\_\_\_\_ Date \_\_\_\_\_

FOD PSO verification (after action completed, or verified) \_\_\_\_\_ Date \_\_\_\_\_

System Owner Signature (sign when action completed) \_\_\_\_\_ Date \_\_\_\_\_

<sup>63</sup> This data sheet accomplishes the requirements of ASME B31.3 Paras. 301.2.1, 301.2.2

**FM09  
Thrust Consideration Data Sheet<sup>64</sup>**

This form is to be used for all manual valves, nozzles, relief devices, solenoid valves, (etc.) in a system that discharge to the ambient surroundings.

Component Identification String	Fluid	I.D. of nozzle/tubing at discharge (inches)	Maximum source pressure (PSIG)	Maximum surge/sustained thrust (lbf)	Type of Restraint Mechanism (if any) Installed.	Maximum Loading (lbs) Restraint Can Withstand <sup>65</sup>
				/		
				/		
				/		
				/		
				/		

<sup>64</sup> This Data Sheet accomplishes the requirements of ASME B31.3 Paragraph 301.5.5, 322.6.2, and Appendix G

<sup>65</sup> As determined by manufacturers' documentation, Finite Element Analysis, calculations, catalog description, etc.

**FM10  
Relief Device Sizing Sketch Sheet (Sample)**

Sketch below the portion of the relief system to be analyzed. Sketch should be an accurate representation of physical relief system layout with dimensions. Use additional sheets for additional relief devices. Do not sketch multiple relief systems on a single sheet. CAD drawings may be attached to this sheet\*.

System I.D.#	Relief Device Component I.D.	Sketcher/Evaluator Name	Date

\*Using software such as ABZ inc. DFS DesignNet or similar software prints for validation of relief device capacity is also acceptable in place of hand or CAD sketches, provided the variables used in the model are attached to this document, and the software has been validated and verified (V&V).