

ASME IX TEST POSITIONS

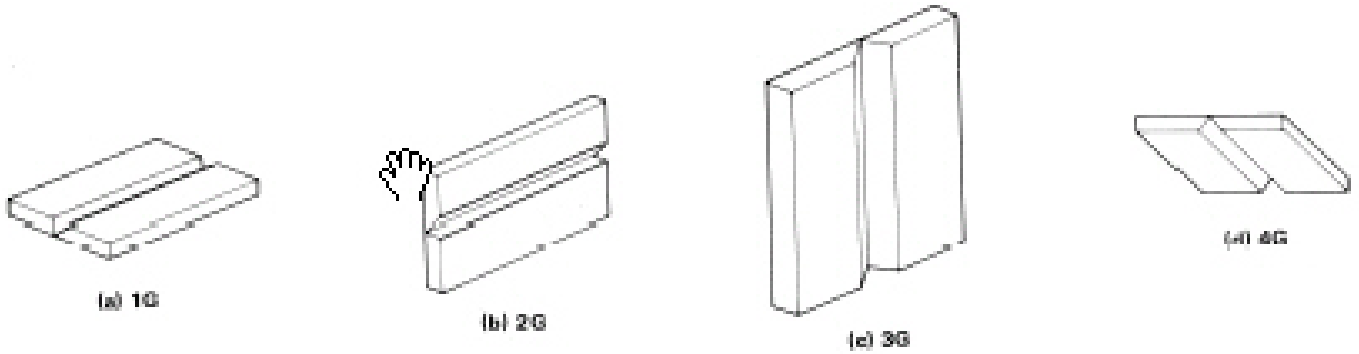

QW-461.3 GROOVE WELDS IN PLATE — TEST POSITIONS

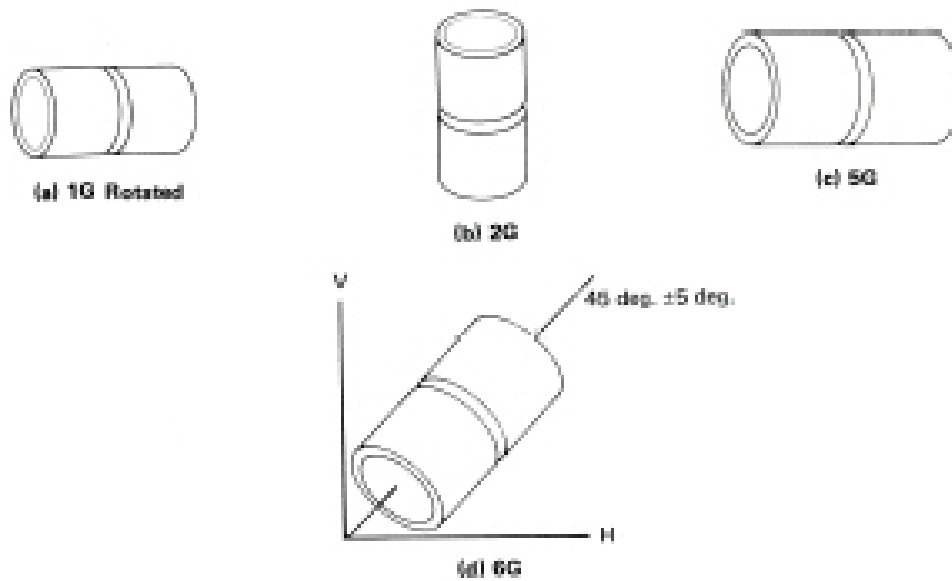

QW-461.4 GROOVE WELDS IN PIPE — TEST POSITIONS