

WELD JOINT DESIGNS FOR ASME, API, AWWA, AND NON-CODE APPLICATIONS

Full Penetration Welds

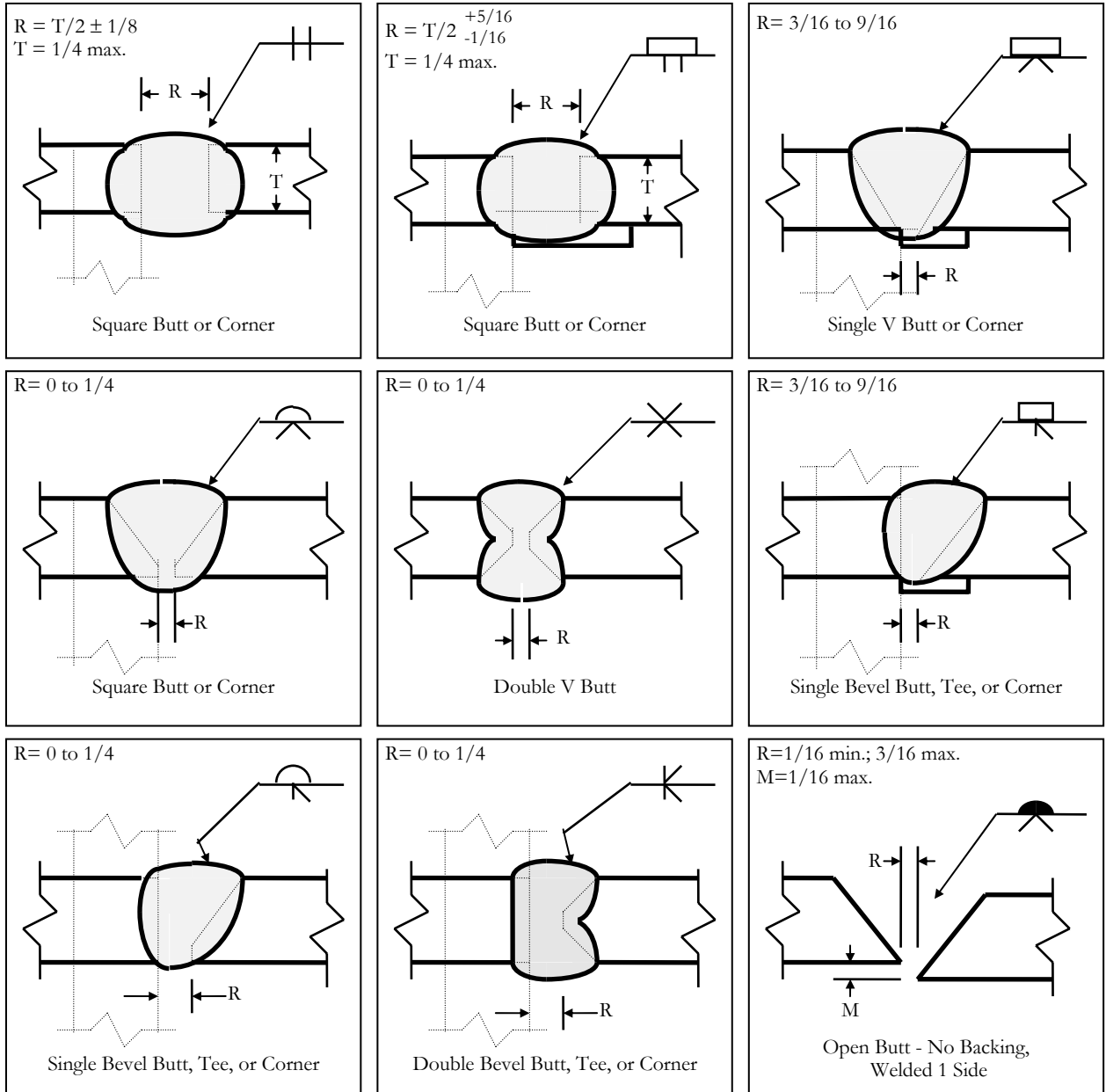

Full Penetration Welds with Inserts

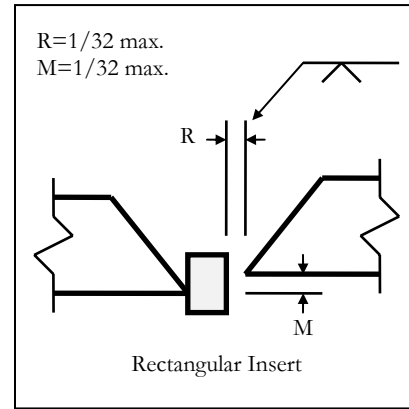
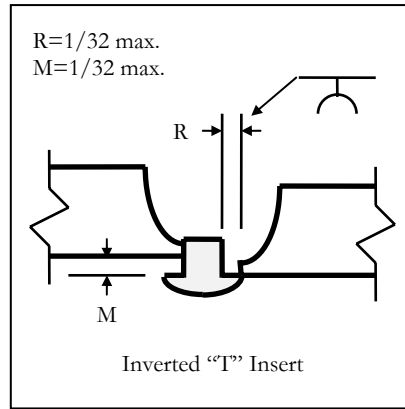

Fillet Weld Joints

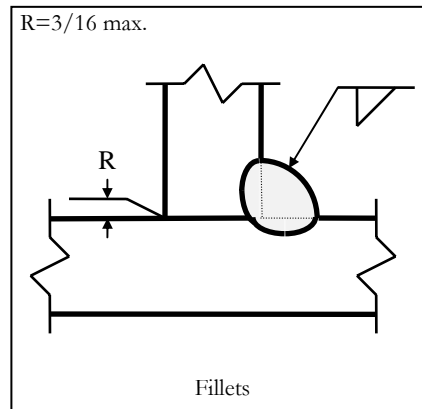

Partial Penetration Weld Joints

