

1.0 JOINT FIT-UP AND ALIGNMENT

- 1.1 For piping systems that operate at hoop stress of less than 20% and the internal adjoining ends do not vary more than $\frac{1}{8}$ in. and adequate penetration and fusion can be obtained no special treatment is necessary. If the offset is greater than $\frac{1}{8}$ in. the following shall apply.
- 1.2 For piping systems that operate at hoop stress of 20% or more of the Specified Minimum Yield Strength the following shall apply.
 - 1.2.1 If the internal adjoining ends do not vary more than $\frac{3}{32}$ in. and adequate penetration and fusion can be obtained no special treatment is necessary. See Figure 14 of this Attachment.
 - 1.2.2 Where the nominal internal offset is greater than $\frac{3}{32}$ in. and no access to the inside for welding, a transition shall be made to the thicker section not to exceed 30° (3:1 taper) or less than 15° (1 $\frac{1}{2}$:1 taper). See Figure 15 of this Attachment.
 - 1.2.3 Where the nominal internal offset is greater than $\frac{3}{32}$ in. but does not exceed $\frac{1}{2}$ the thinner section and there is access to the inside for welding, the transition may be made with a tapered weld or transition as described in paragraph 9.2.2 shall be performed. See Figure 15 of this Attachment.
 - 1.2.4 Where the nominal internal offset is more than $\frac{1}{2}$ the thinner section and there is access for welding, the transition may be made with taper cut or by a combination taper weld to $\frac{1}{2}$ the thinner section see Figure 15 and taper cut from that point as shown in Figure 15 of Attachment.
- 1.3 Where the external offset does not exceed $\frac{1}{2} t$ of the thinner section, the transition may be made by welding as shown by Figure 15 of this Attachment, provided the angle of the rise of the weld surface does not exceed 30° (3:1 taper) and both bevel edges are properly fused. Where there is an external offset exceeding $\frac{1}{2}$ the thinner section, that portion of the offset over $\frac{1}{2} t$ shall be tapered as shown in Figure 15 of this Attachment.
- 1.4 The root opening and fit-up tolerances shall be as specified in the weld joint design in this Attachment as applicable. If the tolerances cannot be achieved, the end preparations may be built up by welding (with an approved WPS or WTS) or re-prepped by machining or grinding.
- 1.5 Parts to be joined by a tee or fillet weld shall be brought into as close contact as is practicable. The maximum gap between these parts shall not exceed $\frac{1}{8}$ in. If the separation is greater than $\frac{1}{16}$ in., each leg of the fillet weld shall be increased by the amount of separation.

Section WFP 2-01 – Welding Fabrication Procedure

Rev. 1, 10/27/06

Attachment 3, ASME B31.8, Gas Transmission & Distribution Piping Alignment and Acceptance Criteria

- 1.6 In assembly of socket weld joints, the pipe or tube shall be withdrawn a distance of approximately $\frac{1}{16}$ in. away from contact between the end of the pipe and the face of the shoulder of the socket. In sleeve-type joints without an internal shoulder, there shall be a distance of approximately $\frac{1}{16}$ in. between the butting ends of the pipe or tube and the butting ends shall be centered in the sleeve. **Note:** Gap inserts (Gapalets or equivalent) and approved shims may be used with prior approval from the design engineer or LANL Welding Program Administrator.

2.0 ACCEPTANCE CRITERIA FOR COMPLETED WELDS

2.1 Butt Welds

- 2.1.1 The quality of welding shall be checked visually on a sampling basis (see paragraph 2.1.3) and defective welds shall be removed and replaced or repaired in accordance with the original WPS or WTS as applicable
- 2.1.2 The quality of welds shall also be examined by nondestructive examination (NDE) methods. The NDE method may consist of radiography, magnetic particle or any other acceptable NDE method.
- 2.1.3 The following is the minimum number of welds that shall be selected on a random basis from each day's production. Each weld shall be examined visually and accepted prior to being examined by an NDE method. Each weld selected shall be examined for the entire circumference. If only part of the weld circumference is to be examined, the responsible engineer or LANL WPA shall approve the selection process prior to its implementation. The same criteria shall be applied to piping systems double ending at railheads or yards.
- 10% of welds in Location Class 1
 - 15% of welds in Location Class 2
 - 40% of welds in Location Class 3
 - 75% of welds in Location Class 4
 - 100% of welds in compressor stations, and at major or navigable river crossings, major highway crossings and railroad crossings, if practical, but in any case not less than 90%. All tie-in welds not subjected to a positive pressure proof test shall be examined.

See page 9 for pipe system classification criteria.

- 2.1.4 Welds that are examined visually shall meet the visual acceptance standards of API 1104. See WFP 2-03, Welding Fabrication Procedure for API 1104 Welding of Pipelines and Related Facilities section of this program. The results of visual examination shall be used to control the quality of the welding.

Section WFP 2-01 – Welding Fabrication Procedure

Rev. 1, 10/27/06

Attachment 3, ASME B31.8, Gas Transmission & Distribution Piping Alignment and Acceptance Criteria

- 2.1.5 When radiography or other NDE methods are employed, the procedure shall meet the requirements of API 1104.
 - 2.1.6 When the pipe size is less NPS 6 or the project involves a limited number of welds that NDE examination would be impractical, and the system is intended to operate at 40% or less of specified yield strength, then provisions of paragraphs 2.12, 2.13, and 2.1.5 are not mandatory, provided the welding is examined visually by a qualified (AWS CWI or equivalent) inspector.
 - 2.1.7 In addition to the NDE requirements qualified (AWS CWI or equivalent) weld inspection personnel continually (surveillance basis) control the quality of the in-process welding.
 - 2.1.8 As-welded surfaces are permitted; however, the surface of welds shall be sufficiently free from coarse ripples, grooves, overlaps, abrupt ridges, and valleys.
 - 2.1.9 The surface condition of the finished welds shall be suitable for the proper interpretation of radiographic and other nondestructive examinations when nondestructive examinations are required. Surface preparation, when required for RT, PT, MT, or UT shall have a minimum of a 250 RMS or equivalent finish.
 - 2.1.10 In those cases where there is a question regarding the surface condition on the radiographic film, the film shall be compared (overlay) to the actual weld surface for interpretation and determination of acceptability.
- 2.2 Socket and Fillet Welds
- 2.2.1 As-welded surfaces are permitted; however, the surface of welds shall be sufficiently free from coarse ripples, grooves, overlaps, abrupt ridges, and valleys.
 - 2.2.2 The surface condition of finished socket and fillet welds shall be suitable for the proper interpretation of nondestructive examinations, where required. Surface preparation, when required for PT, MT, or UT shall have a minimum of a 250 RMS or equivalent finish.
 - 2.2.3 Socket and fillet welds may vary from convex to concave. The size of a fillet weld is determined as shown in the Figure 12. Typical minimum fillet weld details for slip-on flanges and socket-welding components are also contained in Figure 16 of this Attachment.

Figure 12
FILLET WELD PROFILES AND DIMENSIONS

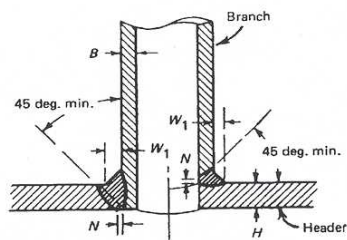

GENERAL NOTES:

- (a) When a welding saddle is used, it shall be inserted over this type of connection.
- (b) $W_1 = 3B/8$, but not less than 1/4 in.
- (c) $N = 1/16$ in. min., 1/8 in. max., unless back welded or backing strip is used.

FIG. 11 WELDING DETAILS FOR OPENINGS WITHOUT REINFORCEMENT OTHER THAN THAT IN HEADER AND BRANCH WALLS

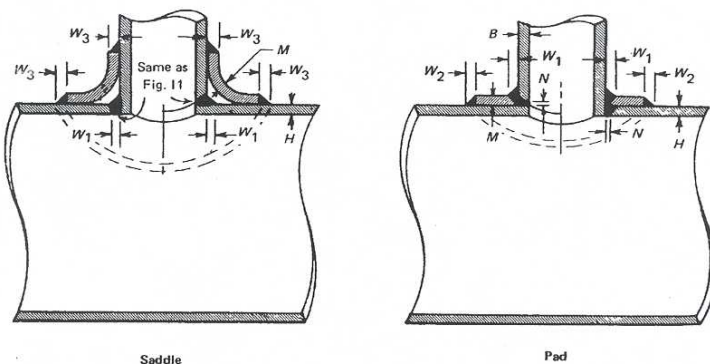

- W_1 min. = $3B/8$, but not less than 1/4 in.
- W_2 min. = $M/2$, but not less than 1/4 in.
- W_3 min. = M , but not greater than H
- $N = 1/16$ in. min., unless back welded or backing strip is used

GENERAL NOTES:

- (a) All welds to have equal leg dimensions, and a minimum throat = 0.707 X leg dimension.
- (b) If M is thicker than H , the reinforcing member shall be tapered down to the header wall thickness.
- (c) Provide hole in reinforcement to reveal leakage in buried welds and to provide venting during welding and heat treatment [See para 831.41 (h)]

FIG. 12 WELDING DETAILS FOR OPENINGS WITH LOCALIZED TYPE REINFORCEMENT

Figure 14
PREPARATION FOR BUTT WELDING

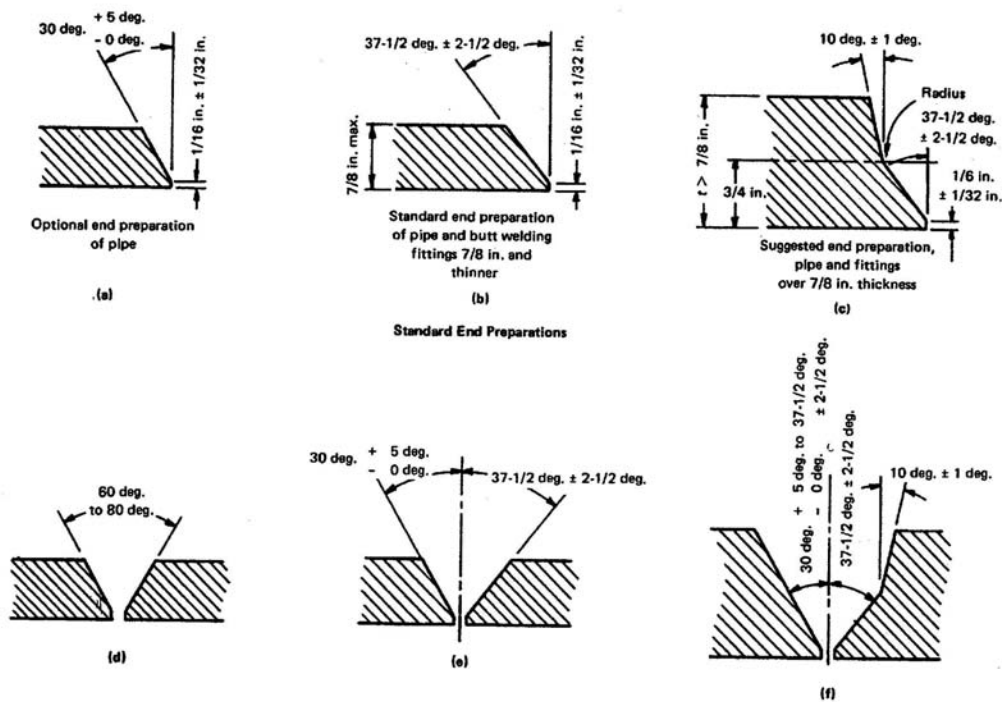

FIG. 14 ACCEPTABLE COMBINATIONS OF PIPE END PREPARATIONS

Figure 15
Acceptable Design for Unequal Wall Thickness

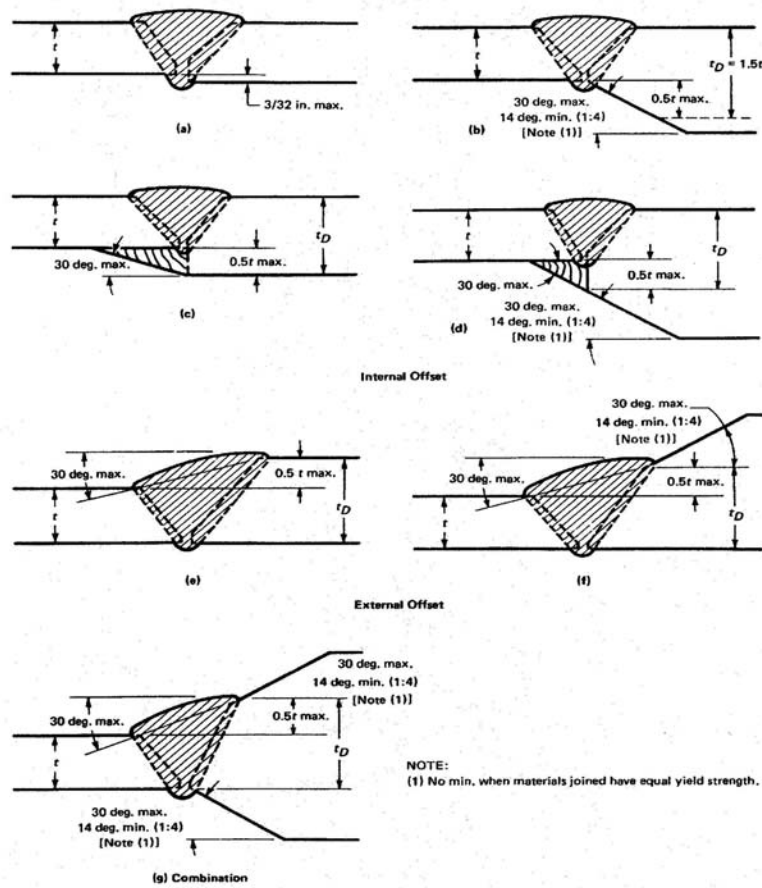

FIG. 15 ACCEPTABLE DESIGN FOR UNEQUAL WALL THICKNESS

Figure 16
Recommended Attachment Details for Flanges

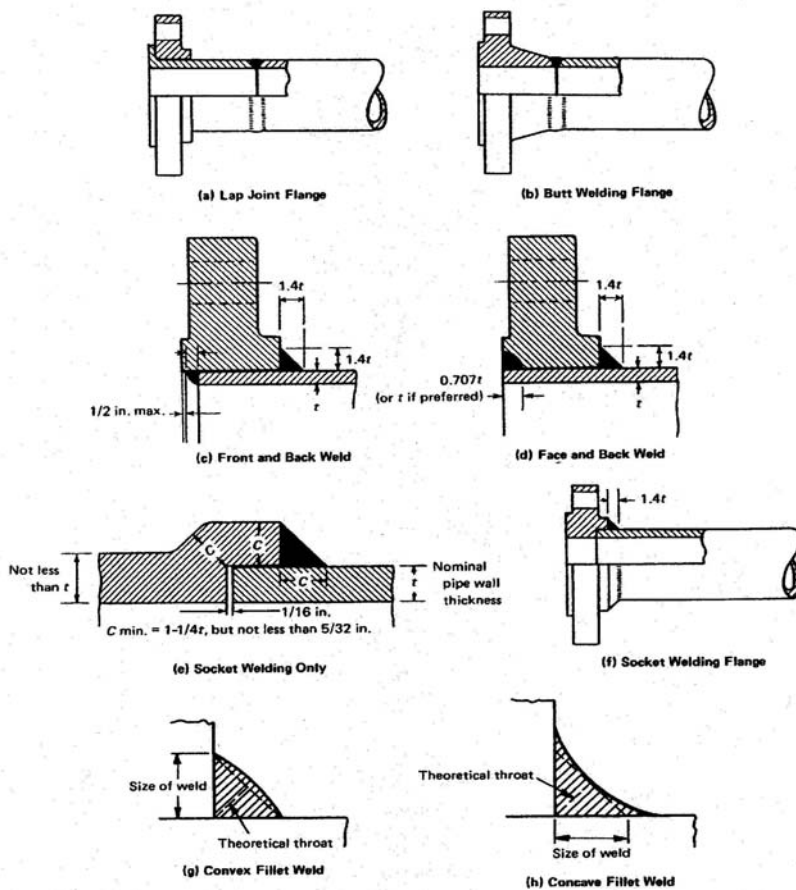

FIG. 16 RECOMMENDED ATTACHMENT DETAILS OF FLANGES

ASME B31.8 SYSTEM CLASS CRITERIA

Location Class 1 – A Location Class 1 is any 1 mile (1.6 km) section that has 10 or fewer buildings intended for human occupancy. A Location Class 1 is intended to reflect areas such as wasteland, deserts, mountains, grazing land, farmland, and sparsely populated areas.

- a. Class 1 Division 1 – A Location Class 1 where the design factor of the pipe is greater than 0.72 but equal to or less than 0.80, and which has been hydrostatically tested to 1.25 times the maximum operating pressure. See Table 841.114B of ASME B31.8 for exceptions to the design factor.
- b. Class 1 Division 2 - A Location Class 1 where the design factor of the pipe is equal to or less than 0.72 but equal to or less than 0.80, and which has been hydrostatically tested to 1.1 times the maximum operating pressure. See Table 841.114B of ASME B31.8 for exceptions to the design factor.

Location Class 2 - A Location Class 2 is any 1 mile (1.6 km) section that has more than 10 but fewer than 46 buildings intended for human occupancy. A Location Class 2 is intended to reflect areas where the degree of population is intermediate between Location Class 1 and Location Class 3 such as fringe areas around cities and towns, industrial areas, ranch or country estates, etc.

Location Class 3 - A Location Class 3 is any 1 mile (1.6 km) section that has 46 or more buildings intended for human occupancy except when a Location Class 4 prevails. A Location Class 3 is intended to reflect areas such as suburban housing developments, shopping centers, residential areas, industrial areas, and other populated areas not meeting Location Class 4 requirements.

Location Class 4 – Location Class 4 includes areas where multi-story buildings are prevalent, and where traffic is heavy or dense and where there may be numerous other utilities underground. Multistory means 4 or more floors above ground including the first or ground floor. The depth of basements or number of basement floors is immaterial.