

TABLE OF CONTENTS

1.0 Scope 2

2.0 References 2

3.0 Definitions..... 2

4.0 Requirements..... 3

5.0 Procedure Qualification and Demonstration 7

6.0 Procedure – General..... 7

7.0 Procedure – Instrument Setup 8

8.0 Procedure – PAUT Calibration..... 8

9.0 Procedure – Verification of Calibration and Recalibration 9

10.0 Procedure – Scanning, Girth Weld 10

11.0 Procedure – Scanning, Nozzle Welds 11

12.0 Evaluation of PAUT Data - General..... 12

13.0 Evaluation of PAUT Data – Acceptance Criteria..... 12

14.0 Reporting of Results..... 14

15.0 Appendices..... 14

RECORD OF REVISIONS

Rev.	Date	Description	POC	RM
0	12/19/2022	Initial issue.	David Harvey <i>ES-FE</i>	Sarah Murdock <i>ES-DO</i>

1.0 Scope

- A. This Procedure provides the steps for performance of Phased Array Ultrasonic Testing (PAUT) on hemispherical vessel configurations for initial acceptance or in-use Fitness for Service assessment. These examinations shall be performed for axially oriented discontinuities. The Code-required transverse and straight beam examinations are performed using approved procedures employing “conventional” manual ultrasonic techniques.
- B. This Procedure has been prepared to comply with the 2015 ASME Boiler and Pressure Vessel Code (BPVC), Section VIII, Division 3, Part KE and Section V, Article 4 including Mandatory Appendices I, II, V, VIII and IX.
- C. This procedure is designed for application to 3’ – 6’ diameter hemispherical vessels, with thicknesses from 1 – 2.5.”
 - 1. Application to other diameters or thicknesses will require modification of this procedure and demonstration on the required blocks.
 - 2. This procedure is applicable only to spherical vessels.

2.0 References

- A. ASME Boiler and Pressure Vessel Code, Section VIII, Division 3, Part KE, 2015 Edition.
- B. ASME Boiler and Pressure Vessel Code, Section V, Article 4, 2015 Edition, including Mandatory Appendices I, II, V, VIII, and IX.
- C. ANSI/ASNT CP-189, *Standard for Qualification and Certification of Nondestructive Testing Personnel*, 2020 Edition.
- D. LANL Engineering Standards Manual STD-342-100, Chapter 13, WIGN 6-02 including Attachment 1, current revision, *Written Practice for NDE Personnel Qualification and Certification*.
- E. LANL Quality Assurance Program, SD330, Revision 12.
- F. LANL Procedure P330-5, Revision 6, *Special Processes*.

3.0 Definitions

- A. FSH – Full Screen Height, the amplitude of a signal described in a percentage of full scale (0-100%).
- B. SDH – Side Drilled Hole, used as a reference reflector for instrument standardization.
- C. Calibration – Referring to the ultrasonic instrument, the process of using an appropriate reference standard to obtain a reproducible response.
- D. Examination – in the parlance of the ASME Codes, examination is the application of nondestructive testing methods to material, a part, component, or system, in this case the method being PAUT. Outside of ASME, the terms used may be test or inspect.
- E. TCG – Time Corrected Gain, an electronic function which adds or subtracts gain as a function of material thickness or sound travel distance to provide equivalent response from a given reflector size at different distances from the probe.

- F. DAC – Distance-Amplitude Curve or Correction
- G. PAUT – Phased Array Ultrasonic Testing
- H. UT – Ultrasonic Testing, see “Conventional”, below.
- I. Conventional – Used in reference to UT, refers in this procedure to techniques using one or two probes, each of either single or dual element design.
- J. Demonstration – Performance of the operational steps of the procedure by a qualified and certified Ultrasonic Phased Array Level II or Level III, resulting in successful detection of the required discontinuities in demonstration blocks designed per ASME BPVC Section VIII, Division 3.
- K. Qualification – Per the ASME Boiler and Pressure Vessel Code, the performance of the procedure steps by a certified PAUT Level II or Level III to demonstrate that the procedure is capable of detection, and allowing accurate evaluation, of the intentional discontinuities in the demonstration blocks designed per ASME BPVC
- L. Essential Variables – as defined in the applicable ASME Boiler and Pressure Vessel Code sections, those procedural elements which may not be changed without requiring Qualification of the procedure.
- M. Performance – the act of executing any steps of this procedure, including scanning, acquisition of data, or evaluation of data and interpretation of results.
- N. Scan Plan – the examination and scanning plan developed in accordance with the requirements of this procedure, which describes equipment, focal laws, scan offsets, scan rate or index and more as described herein. Beam Tool™ is the primary software tool used for development of the scan plan, and may be supplemented by use of component drawings, plots, or other means. The scan plan utilized in conjunction with this procedure shall be demonstrated prior to use, by successful completion of the demonstration/qualification process noted in this procedure. Changes to the scan plan always require demonstration/qualification of the procedure.

4.0 Requirements

- A. Essential Variables – the essential variables for this procedure are given in Table 1. Changes to those items noted as an essential variable requires qualification/ demonstration of this procedure. A change to either an essential variable or a nonessential variable requires revision of or an addendum to this procedure, and demonstration of procedure performance as described in this procedure. Refer to WIGN 6-02 for direction on procedure modification when in-use.

Table 1. Essential and Nonessential Variables		
Requirement	Essential Variable	Nonessential Variable
Weld configurations to be examined, including thickness dimensions and base material product form	X	
The surfaces from which the examination shall be performed	X	
Technique(s) (straight beam, angle beam, etc.)	X	
Angle(s) and mode(s) of wave propagation	X	
Search unit (element pitch, size, number, and gap dimensions)	X	
Focal range(s)	X	

Virtual aperture size(s)	X	
Wedge natural refracted angle	X	
Additional E-scan requirements	X	
Rastering angle(s)	X	
Aperture start and stop element numbers	X	
Aperture incremental changes (# elements stepped)	X	
Additional S-Scan requirements	X	
Sweep angular range(s)	X	
Angular sweep increment (incremental change, degrees)	X	
Aperture element numbers (first and last)	X	
Special search units, wedges, shoes, if used	X	
Ultrasonic Instrument(s)	X	
Standardization (block(s) and technique(s))	X	
Scan Plan	X	
Scanning Technique (manual, semiautomatic, automatic)	X	
Search unit mechanical fixturing device (manufacturer and model)	X	
Scanner and adhering and guiding mechanism	X	
Method for discriminating geometry from flaw indications	X	
Flaw sizing methodology	X	
Computer enhanced data acquisition	X	
Software revision	X	
Scan overlap (decrease <i>only</i>)	X	
Personnel performance requirements	X	
Personnel qualification requirements		X
Surface condition (examination surface, reference standard)		X
Couplant: Brand name or type		X
Post-examination cleaning technique		X
Automatic alarm and/or recording equipment		X
Records, including minimum standardization data to be recorded		X
Weld axis reference point marking		X

- B. Personnel – Personnel performing examinations per this procedure shall be properly qualified and certified in accordance with the current revision of WIGN 6-02, Attachment 1, which meets the requirements of ANSI/ASNT CP-189. All nondestructive examinations shall be performed by, and the results interpreted by, qualified and certified nondestructive examination personnel.
1. Personnel performing PAUT shall be certified as Level II in UT prior to certification as Level II in PAUT.
 2. Personnel shall have specific training on the instrument system and software used. In the case of this procedure, personnel shall have had training in the use of the Olympus (Evident) OmniScan system and OmniPC.
 3. All personnel acquiring, evaluating, or performing final review of data shall have successfully performed the procedure demonstration as described this procedure.
- C. Scan Plans – scan plans are required for all scanning performed in accordance with this procedure. Beam Tool™ is the preferred tool for developing the scan plan, but other methods and tools are acceptable. The scan plan shall address the items below, at

minimum. Changes to the scan plan require revision of the scan plan and qualification/demonstration of this procedure.

1. Scan plan title, date, and revision
 2. Component identification and description
 3. Identification of the weld to be inspected
 4. Description of the weld, e.g., weld design, dimensions, etc.
 5. Directions of scan(s), scan surfaces
 6. Number of scans and required offsets
 7. Instrument and software version
 8. Transducer
 9. Wedge, including wedge natural angle and wedge curvature
 10. Focal range(s)
 11. Virtual probe parameters including number of elements, element width, effective height, and element numbers (first and last), number of elements stepped
 12. Sweep angular range(s), angular increment
- D. Instrumentation – the following instrument may be used with this procedure. Personnel utilizing the listed instrumentation shall have completed specific training in the use of the instrument. Note that a software revision is considered cause for requalification/demonstration of this procedure.
1. Olympus (Evident) OmniScan MX3, software version 5.10.2.
- E. Transducers/Probes
1. Transducers utilized shall be manufactured to be compatible with the instrument selected for use. The transducers and wedges do not have to be manufactured by the instrument manufacturer but shall be compatible and the transducer specifically designed for use with the Olympus Omniscan.
 2. Transducer frequency shall be between 5MHz and 10MHz. Actual frequency used shall be noted in the Scan Plan.
 3. Transducer elements shall be as specified by the design and noted in the Scan Plan.
 4. Transducers used include the following, as defined in the scan plan. Other transducers may be used; however, requalification and revision of this procedure is required:
 - a. 5L-64-A32
 - b. 5L-32-A32
 5. Virtual Probe design shall be as given in the Scan Plan.
 - a. Angular sweep increment shall not be greater than 1°, or if larger sufficient to demonstrate a 50% beam overlap.

- b. Angle ranges shall be selected (and documented in the Scan Plan) to provide coverage of the weld, HAZ, and 2" on each side of the weld. The angle range (for instance, 40°-70°) shall be selected based upon the specific weld configuration as welded and for detection of the flaws in the demonstration block. Multiple scans may be required, using different angle ranges and/or offsets.
6. Wedges/shoes shall be contoured to match the curvature of the vessel being inspected. Wedges/shoes shall have steel wear "studs" installed to reduce wear of the plastic, but care shall be taken to avoid scratching of the surface of the vessel.
7. Wedges used include the following, as defined in the scan plan. Other wedges may be used; however, requalification and revision of this procedure is required:
 - a. SA32-N55S
 - b. SA-32-N55S-IHC
- F. Scanning Apparatus
 1. For scanning of girth or circumferential welds, the Evident (Olympus) AxSEAM scanner shall be used.
 2. For the scanning of nozzle welds, the LANL J-2 probe positioner shall be used.
 3. If needed, straight edges affixed to the vessel surface to provide a hard guide for positioning of the search unit may be used, such as a steel ruler held to the vessel by magnets for examination of the girth welds, or properly shaped guides to examine the nozzles.
 4. Use of other scanning or positioning methodologies requires revision and requalification of this procedure.
 5. Whether scanners or guides are used for positioning of the probe, motion shall be encoded. Encoders shall be calibrated by moving the encoder a minimum distance of 20". The display distance shall be within 1% of the actual distance moved.
- G. Couplant
 1. Couplant shall be Ultragel II or equivalent (equivalence as demonstrated by the ability to successfully set up and standardize/calibrate the instrument). Couplant may be applied manually (direct application from the bottle, brushing or "painting," etc.) or by continuous flow. Continuous flow application may require dilution of the couplant with water, with a maximum of 50% dilution permitted (one part couplant to one part water).
- H. Phased Array Reference Block
 1. The PAUT reference block shall be a block with side-drilled holes at specific known depths. These blocks are used to establish Wedge Delay and Sensitivity calibrations and shall be made of HSLA-100 and of appropriate thickness for the vessel wall being examined.
 2. A schematic representation of this block is given in Appendix 1.

- I. Calibration Standards
 1. The reference standard shall comply with ASME BPVC Section V, Article 4, T-434.
 2. The reference reflectors shall be as specified in ASME BPVC Section V, Article 4, 434.1.1.
 3. The calibration standard shall be made of HSLA-100 (note: there is no P-number assigned to HSLA-100, therefore the standard must be made of the same material).
 4. The calibration standard shall have the same (hemispherical) curvature as the vessel to be examined. Due to the required curvature of the wedges, a flat standard cannot be used.
 5. A schematic representation of this block is given in Appendix 2.

5.0 Procedure Qualification and Demonstration

- A. This procedure shall be considered qualified upon successful demonstration of the procedure on the ASME BPVC Section VIII, Division III, Part KE-301(c) demonstration blocks. There shall be one demonstration block for the girth weld, and at least one demonstration block for the nozzle welds. Nozzle size or joint configuration differences may require more than one demonstration block for a given vessel.
- B. Demonstration blocks shall be fabricated in accordance with the ASME BPVC Section V, Article 4, Mandatory Appendix IX requirements, as modified by Section V, Division III, Part KE, using intentional flaws with an aspect ratio of 0.25.
- C. The initial, qualifying procedure demonstration shall be documented with a report.
- D. All personnel performing PAUT data acquisition or evaluation shall successfully demonstrate performance of the procedure prior to performing duties.
- E. Any change in the essential variables (including adjustments to the scan plan) shall require requalification of this procedure by way of performing successful procedure demonstration in accordance with (d) above. Personnel who have previously demonstrated performance are not required to "re-demonstrate" for essential variable changes unless the Level III deems the changes to be significant.
- F. Detail drawings of the demonstration blocks, including the sizing and method of validation of the intentional discontinuities, shall be approved by the Level III and maintained on file.

6.0 Procedure – General

- A. Welds shall be examined in accordance with the requirements of this procedure, as given in ASME BPVC Section VIII, Division 3. The volume of interest includes the weld and 2" of material on each side of the weld.
- B. The surface shall be free from weld spatter and any roughness which could interfere with the movement of the probe or interfere with transmission of ultrasound. The weld surface shall be free of irregularities which might cause coupling problems or nonrelevant indications.

- C. Straight beam examination of all weld-adjacent base material through which the angle-beam may pass is required prior to angle beam examination and shall be performed in accordance with an approved procedure.
- D. Examination for discontinuities transverse to the weld (sound beam travel parallel to the weld) shall be performed so that the sound beam is parallel to the weld axis. Upon completion of one scan or scan segment in one direction, the probe shall be rotated 180 degrees and the examination repeated. This examination shall be performed using an approved procedure.
- E. Examination for discontinuities parallel to the weld shall be performed using PAUT. This procedure describes that examination.
- F. Refer to WIGN 6-02 for direction on procedure modification when in-use.

7.0 Procedure – Instrument Setup

- A. Instrument Linearity
 - 1. The instrument linearity shall be verified prior to use, either by documentation of a linearity check within the preceding twelve months or by performance of both amplitude control and screen height linearity checks.
 - 2. The instrument shall be checked daily for probe element operability. Use of the Omniscan measurement menu will permit the verification of each element amplitude. If more than 25% of the elements are defective, the probe shall not be used.

8.0 Procedure – PAUT Calibration

- A. PAUT calibration shall include the complete ultrasonic examination system, which includes the instrument, software, cable, probe, wedge/shoe, and couplant. Calibration shall cover the entire sound path used for the examination as specified in the Scan Plan.
- B. At the time of the calibration, the calibration block shall be within 25°F of the vessel being examined.
- C. Focal laws are established and recorded in the Scan Plan. The focal laws established for the scan plan are those used for calibration of the system. Multiple calibrations may be required if more than one scan is performed using different focal laws. If the same set of laws are used in multiple scan offsets, then only one calibration is required for those identical sets of focal laws.
- D. The pulse repetition rate shall be low enough that a signal from a reflector at the maximum sound travel distance in the examination volume will arrive at the transducer before the next pulse is generated.
- E. When the PAUT calibration is recalled from the instrument memory, the calibration shall be verified prior to performance of any examination. The Wedge Delay, Sensitivity, and DAC or TCG shall be verified at the beginning of each day prior to examination.
- F. True Depth and Sensitivity calibrations shall be performed using the OmniScan Wizard.

- G. Time-Corrected-Gain (TCG) calibration shall be performed in the OmniScan Wizard menu, which provides compensation for attenuation in the material at the sound paths used during calibration and examination.
 - 1. The first signal from the PAUT Reference Block shall be set at 80% FSH. This shall be the primary reference level. Indications shall be evaluated with reference to the primary reference gain setting.
- H. Distance-Amplitude-Correction (DAC) may be used for E-scans at specific angles for the purpose of supplemental evaluation of indications.

9.0 Procedure – Verification of Calibration and Recalibration

- A. The initial system calibration shall be performed using the basic calibration block. A simulator block (for instance, an IIW block or DSC, etc.) may be used to verify calibration if the location and amplitude of the simulator reflectors is recorded as part of the calibration record.
- B. System calibration verification shall include the entire PAUT system as defined above. The Sweep Range and TCG calibration shall be verified on the appropriate calibration block or simulator block, as follows:
 - 1. Prior to and within 8 hours of commencing examinations.
 - 2. Upon any change of the same length of instrument-to-probe cable (change of cable length is an essential variable change, requiring requalification of the procedure).
 - 3. With any change of power source (change from AC to battery or change from drained to charged battery including recharging of a battery).
 - 4. Every 4 hours during examination.
 - 5. At the completion of a series of examinations (for instance, completing the scanning of a nozzle at the given offset).
 - 6. At the end of the workday or shift.
 - 7. Whenever the Level II or Level III has reason to believe the calibration may have “drifted” or not be correct.
- C. System Calibration Deviation
 - 1. Distance – if any point has changed more than 10% of the reading or 5% of the full scale, whichever is greater, correct the calibration and record the correction in the examination documentation. All recorded indications since the last successful calibration or verification shall be reexamined and re-recorded.
 - 2. Sensitivity – If any sensitivity setting has changed by more than 20% or 2dB of its amplitude, correct the sensitivity and record the correction in the examination record. If the sensitivity has decreased, all examinations since the last previous calibration or verification shall be voided and the areas rescanned. If sensitivity has been found to have increased, this increase is to be noted in the examination record and all indications noted reevaluated or rescanned.

- D. System Recalibration
 - 1. All of the following shall require recalibration:
 - a. Transducer or wedge change
 - b. Search unit cable type or length change
 - c. PAUT instrument change
 - d. Change in examination personnel
 - e. Change in couplant or couplant dilution
 - f. Change in power source (battery to line, or vice versa; change of battery)

10.0 Procedure – Scanning, Girth Weld

- A. Scanning of the girth weld shall be conducted after the straight beam scans of the weld and the base material through which the angle beams will pass. Specifics of scanning shall be noted in the scan plan as established using Beam Tool™ and verified via successful qualification and demonstration of the procedure.
- B. The girth weld shall be examined from two sides, using the same scan plan and focal laws on each side of the weld unless impeded by nozzles or other fixtures or features on the vessel. The AxSEAM scanner shall be used, when possible, for transducer positioning, movement, and encoding.
- C. The rate of search unit movement shall be slow enough to prevent dropped lines of data. The maximum speed allowed is 6 inches per second, though in practice the scan rate will normally need to be approximately 2 inches per second.
 - 1. The maximum number of dropped lines of data is two lines in any one inch of scan, and there are no adjacent data line skips.
 - 2. Couplant flow must be maintained to minimize data line drops.
- D. Data shall be recorded for the area of interest (weld plus 2" on either side of the weld) in raw (unprocessed) form with no thresholding (reject), at a minimum digitization rate of five times the examination frequency, and maximum recording increments of 0.04". For instance, if using a 5MHz examination frequency, the minimum digitization rate shall be 25MHz. Higher digitization rates are encouraged but will be limited based upon instrument memory and the achievable data transfer rates – a rule of thumb is to utilize the highest rate possible that will not adversely impact scan rates or data line drops.
 - 1. Data may be recorded on the instrument itself, recorded directly to a thumb drive or external drive, or directly to a network storage location.
- E. The Compound-Linear scan is the preferred scanning method and shall be used when possible. Sectorial scans are permitted when necessary, given the configuration of the weld or the desire for continuity from previous fitness-for-service PAUT examinations.
- F. The scanning convention is for two scans, labeled 90 and 270.
 - 1. The 90-scan convention has the sound beam pointed downward with respect to the top port.
 - 2. The 270-scan convention has the sound beam pointed upward with respect to the top port.

- G. Scan segment locations are stamped upon the vessel surface. The segments are chosen based on file sizes allowed with earlier instruments. Scans shall be annotated to identify the scan segment 0–1, 1–2, 2–3, etc., for the given angle (90 or 270). If using instruments with more memory, scans can be longer, but shall contain whole multiples of segments – for instance, 0–2, 2–4, 4–6, etc.
- H. Naming convention of scan segments shall be as follows:
V[vessel #] – circ – [direction] – [distance]offset – [segment]
For instance:
V7-circ-270-2.125offset-0-1
- I. Evaluation of indications shall be performed per Section 12.

11.0 Procedure – Scanning, Nozzle Welds

- A. The nozzle welds shall be scanned from the hemispherical surface of the vessel. If possible, the weld shall also be examined from the ID of the nozzle utilizing an approved straight beam procedure. Specifics of the scanning shall be noted in the scan plan as established using Beam Tool™ and verified via successful qualification and demonstration of the procedure
- B. The J-2 scanning fixture shall be used to maintain the required offset of the probe assembly. The probe shall be encoded using a wheel encoder, either magnetic or pressure type.
- C. The rate of search unit movement shall be slow enough to prevent dropped lines of data. The maximum speed allowed is 6 inches per second, though in practice the scan rate will normally need to be approximately 2 inches per second.
1. The maximum number of dropped lines of data is two lines in any one inch of scan, and there are no adjacent data line skips.
- D. Data shall be recorded for the area of interest (weld plus 2" on either side of the weld) in raw (unprocessed) form with no thresholding (reject), at a minimum digitization rate of five times the examination frequency, and maximum recording increments of 0.04".
- E. The Sectorial scan is the preferred scanning method and shall be used when possible. Compound-Linear scans are permitted, when necessary, given the configuration of the weld or the desire for continuity from previous fitness-for-service PAUT examinations.
- F. Since the nozzle cannot be scanned from two directions, the scan of the nozzle will be performed with the sound beam directed perpendicular to the weld, "aimed" at the center of the nozzle. Scan segment locations are stamped upon the vessel surface. The segments are chosen based on file sizes allowed with earlier instruments. Scans shall be annotated to identify the scan segment 0–1, 1–2, 2–3, etc., for the given angle (270). If using instruments with more memory, scans can be longer, but shall contain whole multiples of segments – for instance, 0–2, 2–4, 4–6, etc.

V [vessel #] – noz[number] – [distance]offset – [segment]

For instance

V7-noz1-1.375-offset-0–1

- G. If the weld joint configuration permits, a straight beam scan from the nozzle ID shall be performed using an approved procedure.

12.0 Evaluation of PAUT Data - General

- A. The following tools are used for evaluation of the data resulting from the PAUT scans:
 - 1. The OmniScan instrument and associated software, used for in-process evaluation
 - 2. OmiPC – desktop software for post-scan evaluation, software version 5.9 or later.
 - 3. Beam Tool – a tool for the verification of indication locations in the vessel or weld. Use of the most recent version is recommended; however, because Beam Tool is not the evaluation software, the software version is not considered an essential variable, nor a nonessential version requiring procedure revision.
- B. Detail steps for use of OmniPC for evaluation are given in Appendix 1.
- C. All PAUT scan data shall be evaluated and interpreted by a PAUT Level II or Level III who has demonstrated competence in PAUT and the use of this procedure by successfully performing the demonstration of this procedure on the demonstration blocks required for the given vessel.
- D. The final data package shall be reviewed by a UT Level III. The review shall include:
 - 1. The ultrasonic data record
 - 2. Data interpretations
 - 3. Flaw evaluations/characterizations performed by another qualified Level II or Level III individual.

The Level III performing the data package review shall not have been a participant in acquiring or analyzing data for the report. The reviewing Level III shall be qualified as Level II PAUT and shall have had a practical examination on flawed specimens.

13.0 Evaluation of PAUT Data – Acceptance Criteria

- A. Refer to Appendix 3 for detail steps for evaluation.
- B. Any reflector which exceeds 20% of the reference level (16% FSH with a TCG established at 80%) at reference sensitivity shall be evaluated.
- C. Indication Classification - All indications exceeding 20% of the reference level shall be evaluated to determine whether the indication originates from a flaw or is a geometric indication.
- D. Geometric Indications – Ultrasonic indications of geometric and metallurgical origin shall be classified as follows:
 - 1. Indications that are determined to originate from surface configurations (such as weld reinforcement of root geometry) or variations in metallurgical structure of materials (such as cladding to base metal interface) may be classified as geometric indications, and
 - a. Need not be characterized and sized,

- b. Need not be compared to allowable flaw acceptance criteria as given in Appendix 4, and
 - c. Shall have the maximum amplitude and location of the indication recorded.
 2. The following steps shall be taken to classify the indication as geometric:
 - a. Interpret the area containing the reflector in accordance with the applicable examination procedure,
 - b. Plot and verify the reflector coordinates, providing a cross-sectional display showing the reflector position and surface discontinuity such as root or counterbore (BeamTool™ may be used to provide this plot),
 - c. Review and compare with fabrication or weld prep drawings.
- E. Flaw Indications – When a reflector is determined to be a flaw, it shall be evaluated as follows:
 1. All flaws shall be evaluated using the acceptance criteria of Appendix 4.
 2. Surface connected flaws – flaws identified as surface connected may or may not be open to the surface.
 - a. Unless UT data analysis confirms that the flaw is not surface connected, it shall be considered open to the surface and is unacceptable.
 - b. If the indication can be verified as not surface connected (open to the surface) using an approved MT or PT procedure, the flaw shall be evaluated in accordance with Appendix 7. If the indication is surface connected, it is unacceptable.
 3. Multiple flaws – multiple discontinuous flaws shall be evaluated as follows:
 - a. Discontinuous flaws shall be considered a singular planar flaw if the distance between adjacent flaws is equal to or less than the dimension S as shown in Appendix 5.
 - b. Discontinuous flaws that are oriented primarily in parallel planes shall be considered a singular flaw if the distance between the adjacent planes is equal to or less than $\frac{1}{2}$ inch. Refer to the figures in Appendix 6.
 - c. Discontinuous flaws that are coplanar and nonaligned in the through-wall thickness direction of the component shall be considered a singular planar flaw if the distance between adjacent flaws is equal to or less than S as shown in Appendix 6.
 - d. Discontinuous flaws that are coplanar in the through-wall direction within two parallel planes $\frac{1}{2}$ inch apart (in other words, normal to the pressure-retaining surface of the component) are unacceptable if the additive flaw depth dimension of the flaws exceeds those shown in Appendix 6.
 4. Subsurface Flaws – Flaw length (l) shall not exceed $4t$.

14.0 Reporting of Results

- A. Evaluation of indications shall be based upon the Acceptance Criteria in Appendices 4, 5 and 6.
- B. Determination of indication acceptability may be performed using a spreadsheet to perform calculations of dimensions and aspect ratios per Appendix 4. Unless the spreadsheet has been verified and LANL-required SQC completed, results of spreadsheet calculations shall be validated manually.
- C. Prior to issue, the data package shall be reviewed, and the results reviewed, by a Level III meeting the qualification requirements of this procedure. Note that this review shall be by a Level III that did not take part in the acquisition and evaluation of the data.
- D. The report of results shall include, at minimum, the following:
 1. Procedure and revision
 2. Component identification
 3. Calibration and reference standard identification
 4. Calibration data
 5. Scan Plans (which include the instrument, software, search unit, welds examined, scan directions, etc., as required by this procedure)
 6. Any regions of restricted access or inaccessible welds
 7. Evaluation software and revision used
 8. Tabulation of indications evaluated and evaluation results
 9. Date(s) of examination
 10. Examination and evaluation personnel identity and certification level
 11. Level III review
- E. All data, including scan data, scan plans, and evaluation tables, shall be transmitted to J-2 for archival storage.
- F. A summary report shall be prepared for J-2 upon completion of data evaluation and review. This report shall be in the form of a memorandum and will summarize the examination and shall include the evaluation results for all indications, the scan plans, and any other information requested by or deemed to benefit J-2.

15.0 Appendices

Appendix 1. Phased Array Reference Standard

Appendix 2. Calibration Standard per ASME Section V, Article 4, T-434

Appendix 3. Detail Steps for Evaluation and Interpretation of PAUT indications

Appendix 4. Guidelines for Characterization of Indications

Appendix 5. ASME BPVC Section VIII, Division 3, KE-301-1, Flaw Acceptance Criteria for 1 in. (25mm) to 12 in. (300mm) Thick Weld

Appendix 6. ASME BPVC Section VIII, Division 3, Figure KE-301-1 Single Indications

Appendix 7. ASME BPVC Section VIII, Division 3, Figures KE-301-2 through KE-301-5 Planar Flaw Orientations for Evaluation

Archive

Appendix 1. Phased Array Reference Standard

The phased array standard shall be designed to facilitate the setup of the instrument, including wedge delay, sensitivity, etc. An example of a phased array reference standard is given below. The actual standard used shall be included in the scan plan.

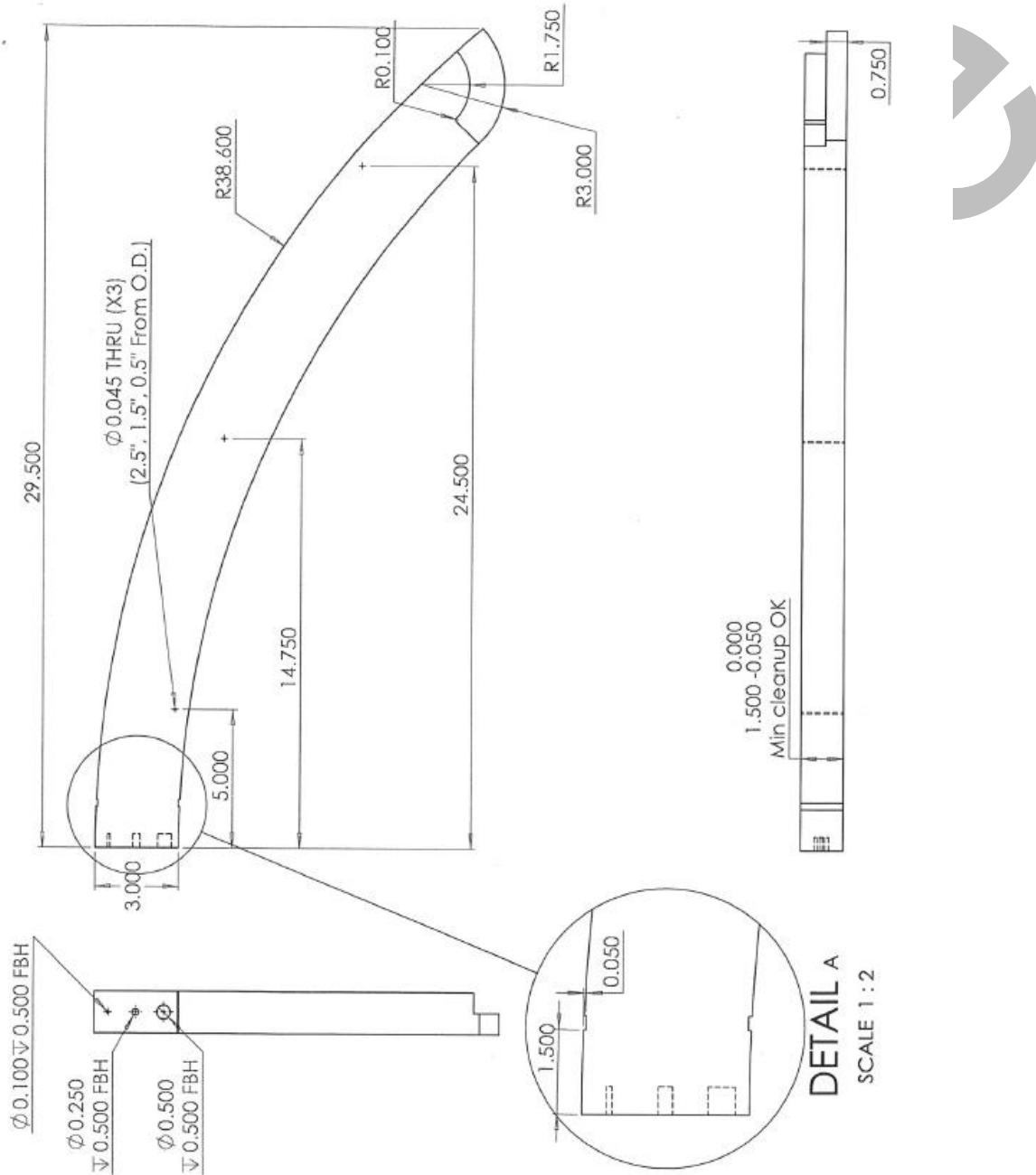

Appendix 2. Calibration Standard per ASME Section V, Article 4, T-434

Below is an example of the Code-required reference standard. The standard used shall allow calibration over the required wall thickness and metal path. A drawing of the reference standard used shall be included in the Scan Plan.

Figure T-434.2.1
Nonpiping Calibration Blocks

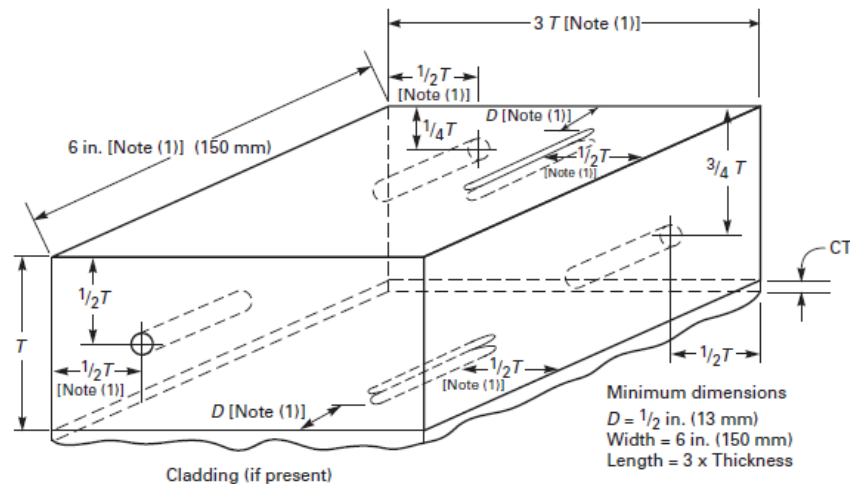

Notch Dimensions, in. (mm)

Notch depth = 1.6% T to 2.2% T
Notch width = 1/4 (6) max.
Notch length = 1 (25) min.

Weld Thickness (t), in. (mm)	Calibration Block Thickness (T), in. (mm)	Hole Diameter, in. (mm)
Up to 1 (25)	3/4 (19) or t	3/32 (2.5)
Over 1 (25) through 2 (50)	1 1/2 (38) or t	1/8 (3)
Over 2 (50) through 4 (100)	3 (75) or t	3/16 (5)
Over 4 (100)	t ±1 (25)	[Note (2)]

GENERAL NOTES:

- (a) Holes shall be drilled and reamed 1.5 in. (38 mm) deep minimum, essentially parallel to the examination surface.
- (b) For components equal to or less than 20 in. (500 mm) in diameter, calibration block diameter shall meet the requirements of T-434.1.7.2. Two sets of calibration reflectors (holes, notches) oriented 90 deg from each other shall be used. Alternatively, two curved calibration blocks may be used.
- (c) The tolerance for hole diameter shall be ±1/32 in. (0.8 mm). The tolerance for hole location through the calibration block thickness (i.e., distance from the examination surface) shall be ±1/16 in. (3 mm).
- (d) For blocks less than 3/4 in. (19 mm) in thickness, only the 1/2 T side-drilled hole and surface notches are required.
- (e) All holes may be located on the same face (side) of the calibration block, provided care is exercised to locate all the reflectors (holes, notches) to prevent one reflector from affecting the indication from another reflector during calibration. Notches may also be in the same plane as the inline holes (see Nonmandatory Appendix J, Figure J-431). As in Figure J-431, a sufficient number of holes shall be provided for both angle and straight beam calibrations at the 1/4 T, 1/2 T, and 3/4 T depths.
- (f) When cladding is present, notch depth on the cladding side of the block shall be increased by the cladding thickness, CT (i.e., 1.6% T + CT minimum to 2.2% T + CT maximum).
- (g) Maximum notch width is not critical. Notches may be made by EDM or with end mills up to 1/4 in. (6.4 mm) in diameter.
- (h) Weld thickness, t, is the nominal material thickness for welds without reinforcement or, for welds with reinforcement, the nominal material thickness plus the estimated weld reinforcement not to exceed the maximum permitted by the referencing Code Section. When two or more base material thicknesses are involved, the calibration block thickness, T, shall be determined by the average thickness of the weld; alternatively, a calibration block based on the greater base material thickness may be used provided the reference reflector size is based upon the average weld thickness.

NOTES:

- (1) Minimum dimension.
- (2) For each increase in weld thickness of 2 in. (50 mm) or fraction thereof over 4 in. (100 mm), the hole diameter shall increase 1/16 in. (1.5 mm).

Appendix 3. Detail Steps for Evaluation and Interpretation of PAUT indications

1. Flaw Indication Evaluation
 - a. Indications are evaluated and interpreted using OmniPC. All references to image presentations, results, or dimension descriptions are based upon the terminology and display provided by the OmniPC software package. Determination of the acceptability of indications is based upon Table KE-301-1 (Appendix 4) and Figures KE-301-1 through KE-301-5 (Appendix 5).
 - b. Flaw Indications – all indications that could be flaws shall be investigated by using the following characteristics of flaw indications. The listed points are not mandatory discriminators to accept or reject an indication but are meant to be a guide in characterizing the indication for final evaluation.
 - 1) The indication has a strong signal to noise ratio (for example, S:N of 2:1) and has well defined start and end points on the baseline. The general noise level experienced along the weld can further support the presence of this characteristic.
 - 2) Plotting the indication (using CAD, pen and paper, or preferably Beam Tool™) shows the indication to be in a location that would be prone to cracking or the presence of lack of fusion or penetration.
 - 3) The indication is observed at multiple sound beam angles, with a higher angle resulting in a higher amplitude signal response.
 - 4) The indication “travels” or “walks”.
 - 5) The indication, along its length, shows multiple peak amplitudes.
 - 6) The indication maintains amplitude or shows an increase in amplitude as the sound beam is skewed away from normal. This property would not be observed during scanning, but during a supplemental evaluation (Note: conventional UT methods maybe used to perform this evaluation, using an approved procedure).
 - 7) Time base positions vary as the search unit is moved along the length of the indication.
 - 8) There is evidence of flaw tip signals from the indication.
 - 9) On the girth weld, circumferential flaws can be seen from the other side of the weld.
 - 10) The indication originates near a geometrical reflector but can be separated from the geometric indication and the indication has variations in amplitude.
 - 11) For nozzle welds, where access can only be achieved from one side, additional search unit angles may be necessary to fully characterize the indication. Care must be taken when evaluating indications in the nozzle welds, since it is possible that there is not corner connection (“corner trap”).

2. Geometric Indication Evaluation

a. Geometric Indications – all indications which are suspected of being of geometric origin must be carefully evaluated before making such an interpretation. The end use of J-2 vessels dictates the critical importance of a correct interpretation when an indication could be geometric. The following characteristics should be considered by the examiner in making a determination of the nature of the indication.

- 1) Indications which are present along the length of the scan but are at angles uncharacteristic of a single geometric reflector and may be present at multiple sound paths or sweep positions. Such indications could be caused by mode-converted signals from the inside surface at lower beam angles.
- 2) The indication can be seen across the whole length of the scan at consistent amplitude and sweep location.
- 3) The indication does not “travel” or “walk”, or such changes along the sweep are minimal.
- 4) The indication provides a rapid and consistent drop in amplitude when the transducer is skewed from normal. Such skewing is not possible during the initial scan but may be performed after data acquisition (Note: conventional UT methods may be used for this verification, using an approved procedure).
- 5) The signal responses are consistent from each side of the girth weld.

3. Indication Location

a. Indication positioning is a challenge on the nozzle welds, and detailed evaluation may be required. The following steps can assist in proper location of indications.

- 1) Perform detailed thickness and surface contour recordings at the location of the indication or indications. Try to identify any offset of the weld root in relation to the weld centerline.
- 2) Compare flawed and unflawed regions, attempting to identify standard “benchmark” responses such as the root, counterbore, etc.
- 3) Plot this information using Beam Tool™ or other similar resources.

4. Length Sizing

a. Length sizing shall be performed from the same side of the weld as the indication, using the C-Scan display. If the component geometry restricts access, or the signal from the indication is improved due to the flaw geometry, sizing from the opposite side of the weld is permitted. Indications in nozzle welds can only be sized from one side since a two-sided scan is not possible.

NOTE: It is critical that the offset and travel along the arc is considered when measuring the length of indications in the nozzle welds – the length of the indication will be shorter than the travel of the search unit.

b. Length sizing is performed at the reference gain setting, using the **6db drop** technique.

NOTE: When measuring the length of an indication, there will often be variations in the signal amplitude along the length of the indication, including the potential for an amplitude drop below 6dB. The examiner must be careful that separation between the indications is considered so that the indication is sized as a single indication or two or more indications, per Figures KE-301-2-5, as shown in Appendix 6.

- c. If the flaw is detectable with multiple PA probe angles, the primary search unit should be used for length determination. If geometric conditions or examination limitations prevent adequate length sizing using the primary search unit, additional angles shall be used. If multiple angles are utilized, the angle providing the worst-case (longest) dimension shall be used.
 - d. If an extreme length discrepancy exists between two search unit angles, an attempt should be made to determine the cause of the discrepancy. If beam spread, geometrical effects, etc. can be determined as the cause for this discrepancy, the examiner may use the result from a search unit giving a less conservative result.
5. Height sizing
- a. As with length sizing, flaw height sizing shall be performed from the same side of the weld as the indication. If the component geometry restricts access, or the signal from the indication is improved due to the flaw geometry, sizing from the opposite side of the weld is permitted. Indications in nozzle welds can only be sized from one side since a two-sided scan is not possible.
 - b. Height sizing is based upon the through-wall height of the flaw, not the width (diagonal), and uses the **3dB** drop technique. This measurement shall be made on the sectoral scan display, not the B-Scan display.

Appendix 4. Guidelines for Characterization of Indications – Indication Characteristics

To characterize indications, the following guidelines may be used. Note that characterization provides supplemental information to the evaluation, as all indications are to be compared to the standard established in Appendix 3.

1. Lack of Root Penetration
 - a. Unique, significant, and very sharp amplitude signal with easily discernable start and stop
 - b. The signal walks or travels
 - c. Similar response when scanned from the opposite direction
 - d. Plots correctly to the centerline of the weld when scanned from two directions
 - e. Measured depth corresponds to weldment design
2. Lack of Sidewall or Interpass Fusion
 - a. Unique, significant, and very sharp amplitude signal with easily discernable start and stop
 - b. The signal walks or travels
 - c. The indication may present upper and lower tip signals
 - d. The response from the opposite direction may be significantly lower in amplitude and observed from a different sound path
3. ID or OD Connected Crack
 - a. Unique, significant, and very sharp amplitude signal with easily discernable start and stop
 - b. The signal walks or travels
 - c. Signals from the flaw base, tip, possible faceting
 - d. Similar response when scanned from the opposite direction
 - e. Plots correctly to the ID or OD location when scanned from two directions
4. Centerline cracking
 - a. Unique, significant, and very sharp amplitude signal with easily discernable start and stop
 - b. The signal walks or travels
 - c. Similar response when scanned from the opposite direction
 - d. Does not connect to ID or OD surfaces
 - e. Plots to the centerline of the weld
5. Porosity
 - a. Multiple signal responses of lower amplitude with varying amplitude and position
 - b. Starts and stops “blend” with background noise
 - c. Plots to the weld volume
6. Slag Inclusion
 - a. Isolated signal responses from within the weld volume
 - b. Usually detectable from both sides of the weld

Appendix 5: ASME BPVC Section VIII, Division 3, KE-301-1, Flaw Acceptance Criteria for 1 in. (25mm) to 12 in. (300mm) Thick Weld

**Table KE-301-1
Flaw Acceptance Criteria for 1 in. (25 mm) to 12 in. (300 mm) Thick Weld**

As- pect Ratio, a/ℓ	1 in. (25 mm) $\leq t \leq 2\frac{1}{2}$ in. (64 mm)		4 in. (100 mm) $\leq t \leq 12$ in. (300 mm)	
	[Note (1)]		[Note (1)]	
	Surface Flaw, a/t	Subsurface Flaw, a/t	Surface Flaw, a/t	Subsurface Flaw, a/t
0.00	0.031	0.034	0.019	0.020
0.05	0.033	0.038	0.020	0.022
0.10	0.036	0.043	0.022	0.025
0.15	0.041	0.049	0.025	0.029
0.20	0.047	0.057	0.028	0.033
0.25	0.055	0.066	0.033	0.038
0.30	0.064	0.078	0.038	0.044
0.35	0.074	0.090	0.044	0.051
0.40	0.083	0.105	0.050	0.058
0.45	0.085	0.123	0.051	0.067
0.50	0.087	0.143	0.052	0.076

GENERAL NOTES:

- t = thickness of the weld excluding any allowable reinforcement. For a butt weld joining two members having different thickness at the weld, t is the thinner of these two thicknesses. If a full penetration weld includes a fillet weld, the thickness of the throat of the fillet weld shall be included in t .
- A subsurface indication shall be considered as a surface flaw if separation (S in Figure KE-301-1) of the indication from the nearest surface of the component is equal to or less than half the through thickness dimension ($2d$ in Figure KE-301-1, illustration [b]) of the subsurface indication.
- If the acceptance criteria in this table results in a flaw length, ℓ , less than 0.25 in. (6.4 mm), a value of 0.25 in. (6.4 mm) may be used.

NOTE:

- (1) For intermediate flaw aspect ratio a/ℓ and thickness t ($2\frac{1}{2}$ in. (64 mm) $< t < 4$ in. (100 mm)) linear interpolation is permissible.

ARC

Appendix 6. ASME BPVC Section VIII, Division 3, Figure KE-301-1 Single Indications

Figure KE-301-1
Single Indications

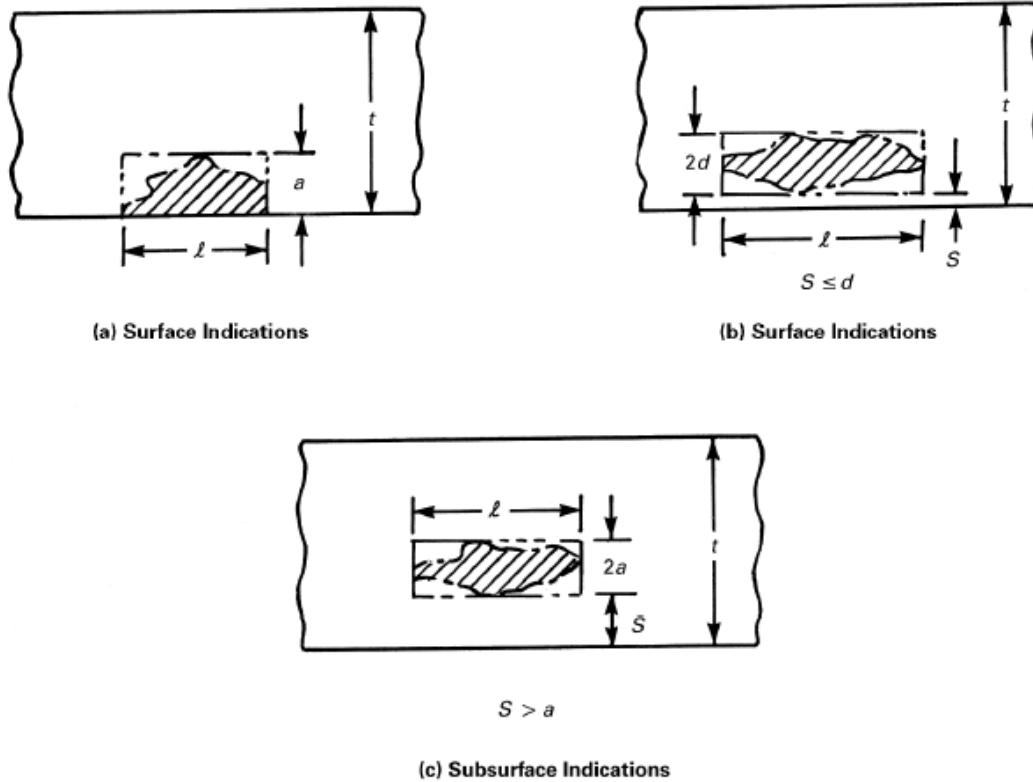

ART

Appendix 7. ASME BPVC Section VIII, Division 3, Figures KE-301-2 through KE-301-5 Planar Flaw Orientations for Evaluation

Figure KE-301-2
Multiple Planar Flaws Oriented in Plane Normal to Pressure-Retaining Surface

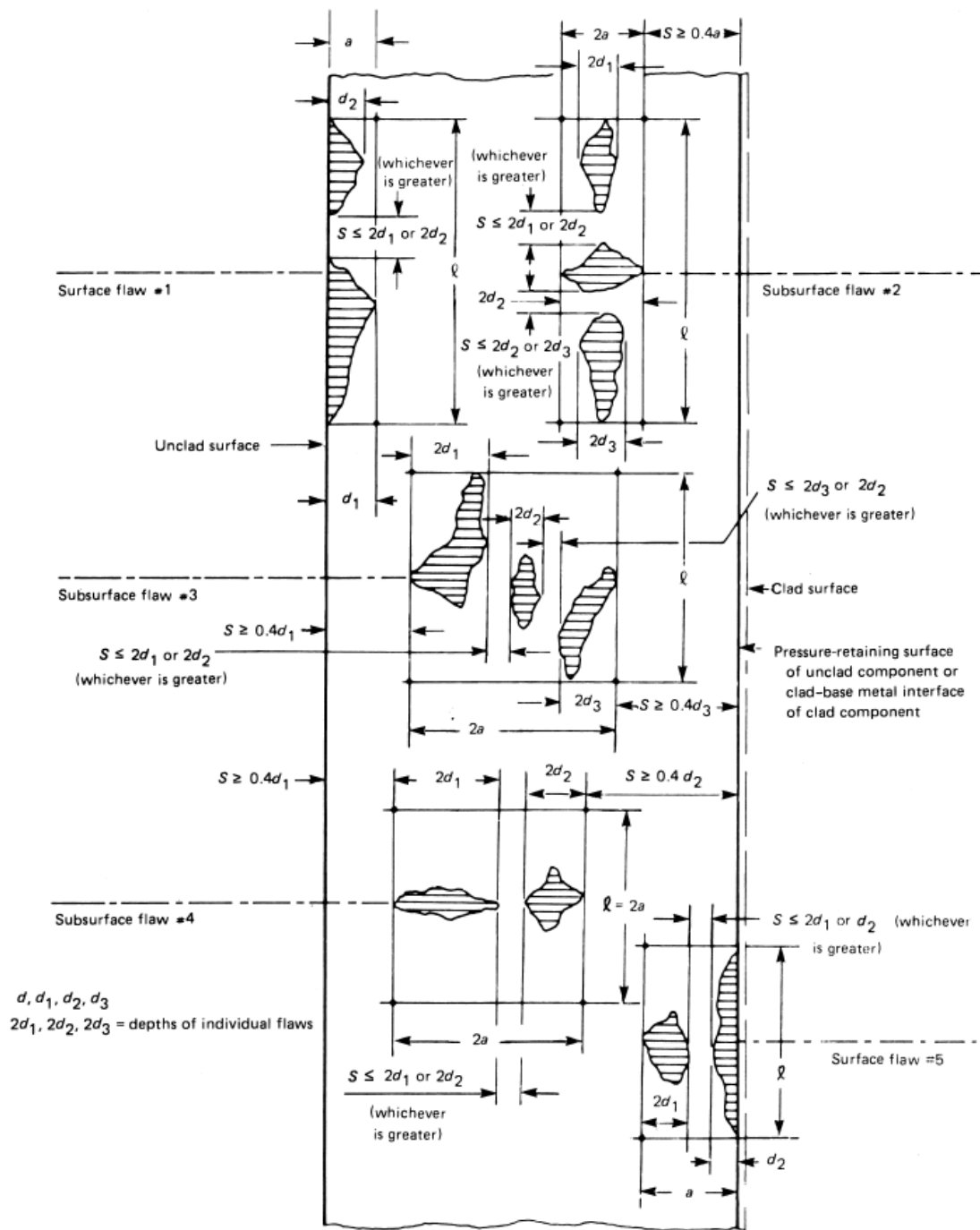

Figure KE-301-3
Parallel Planar Flaws

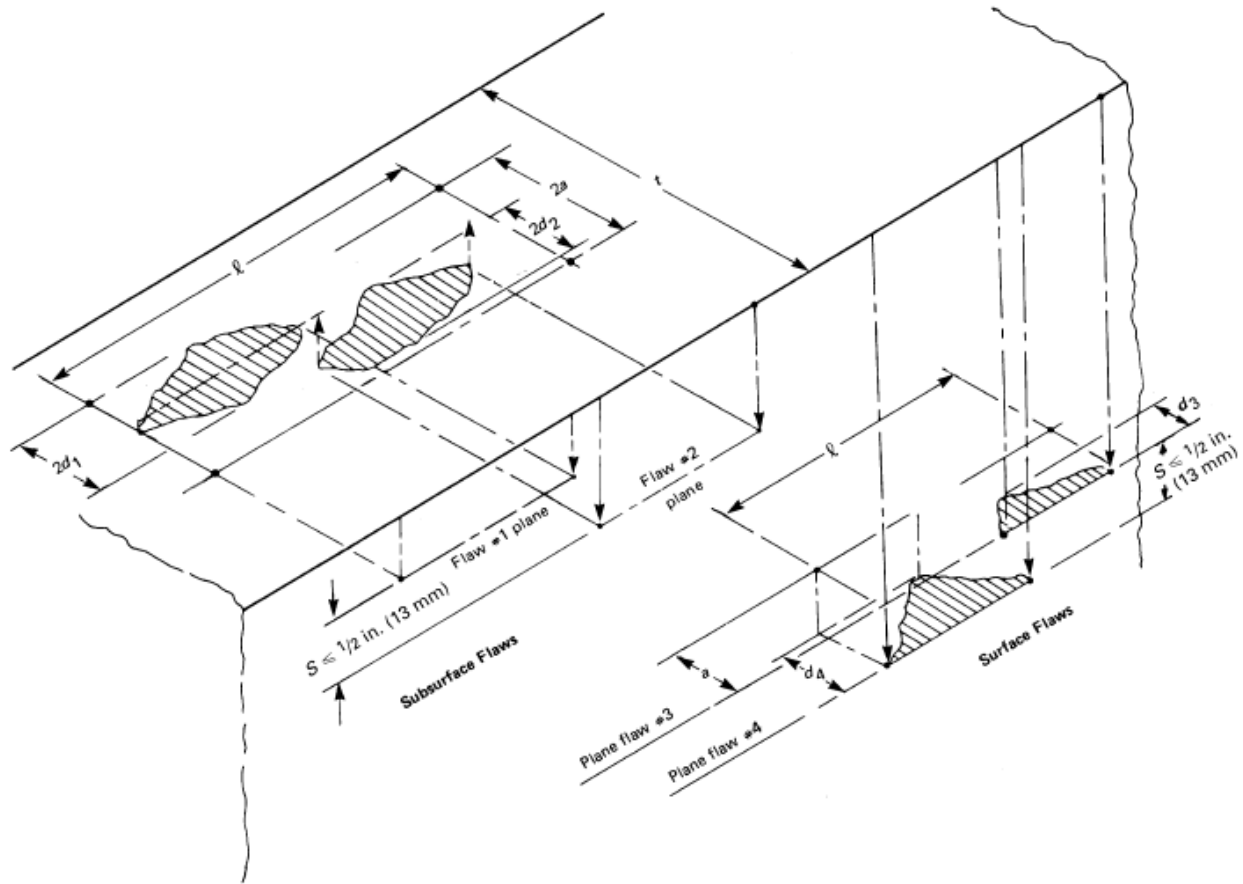

Figure KE-301-4
Nonaligned Coplanar Flaws in Plane Normal to Pressure-Retaining Surface (Illustrative Flaw Configurations)

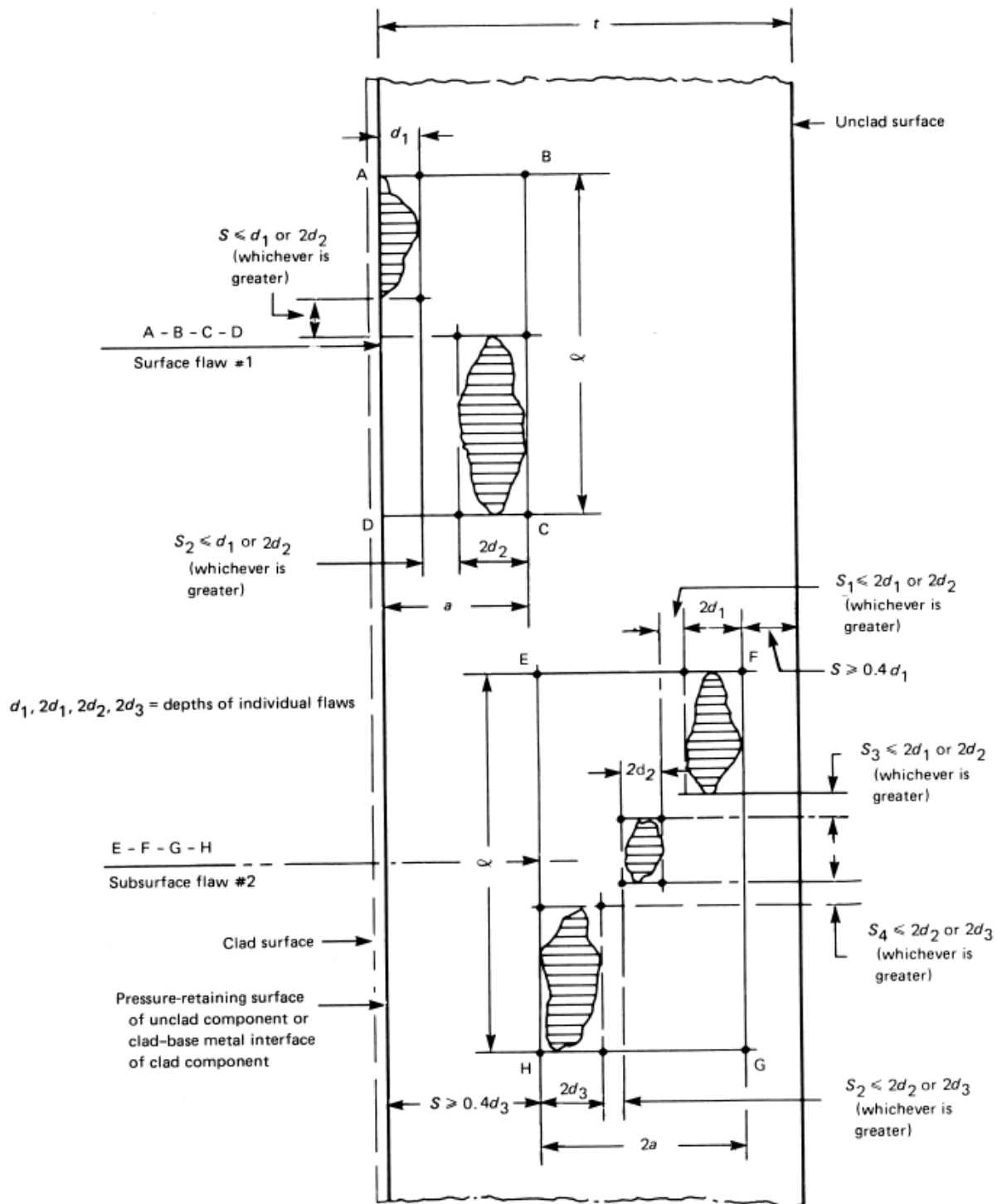
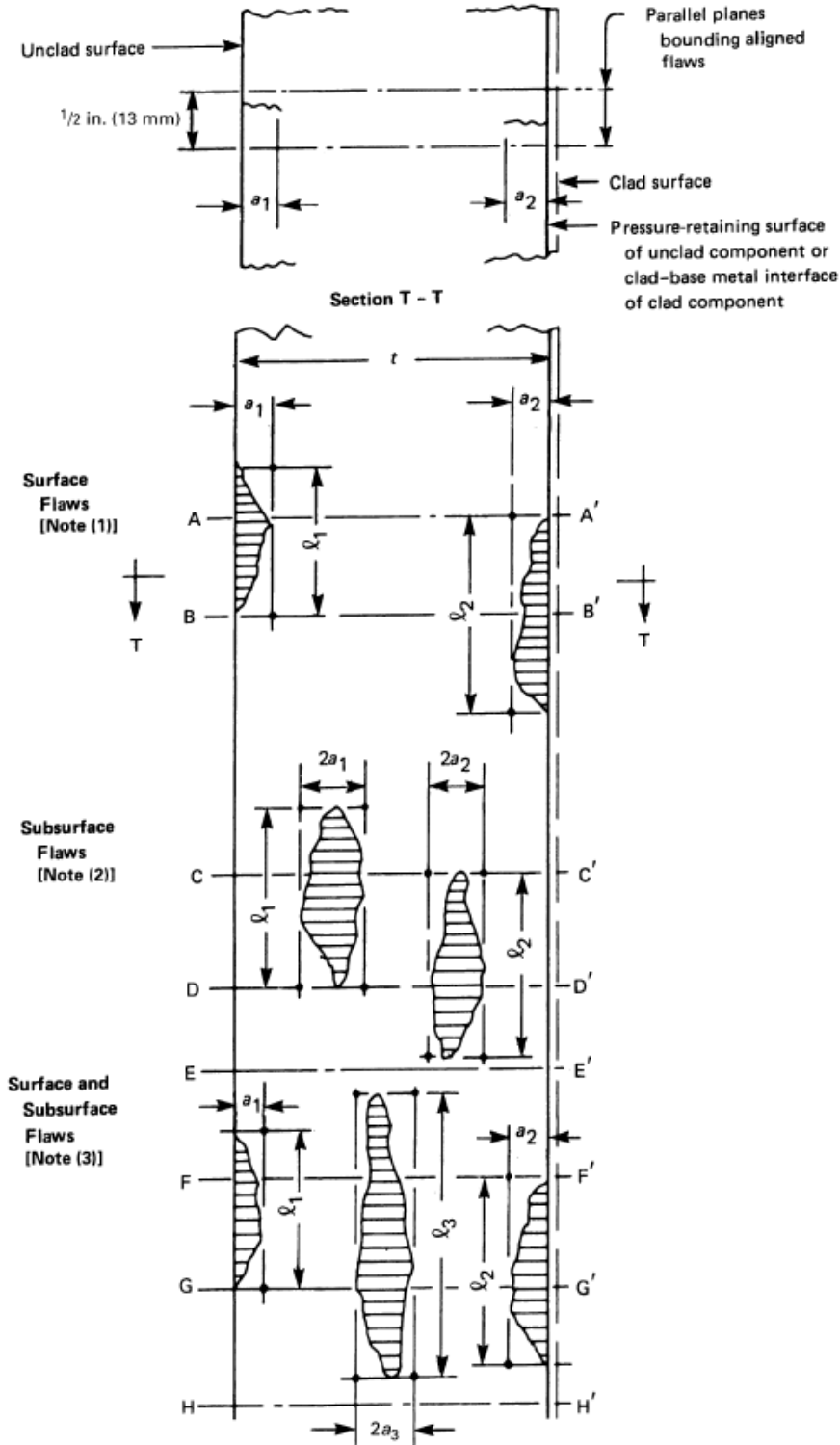

Figure KE-301-5
Multiple Aligned Planar Flaws



GENERAL NOTE: The flaw depth dimensions a_s and a_e are the allowable flaw standards for surface and subsurface flaws, respectively.

**Figure KE-301-5
Multiple Aligned Planar Flaws (Cont'd)**

NOTES:

(1) This illustration indicates two surface flaws. The first, a_1 , is on the outer surface of the component, and the second, a_2 , is on the inner surface:

$$(a_1 + a_2) \leq (a_s + a'_s)/2 \text{ within planes } A-A' \text{ and } B-B'$$

(2) This illustration indicates two subsurface flaws:

$$(a_1 + a_2) \leq (a_e + a'_e)/2 \text{ within planes } C-C' \text{ and } D-D'$$

(3) This illustration indicates two surface flaws and one subsurface flaw:

(a) $(a_1 + a_3) \leq (a_s + a'_e)/2$ within planes $E-E'$ and $F-F'$

(b) $(a_1 + a_2) \leq (a_s + a_e + a'_s)/3$ within planes $F-F'$ and $G-G'$

(c) $(a_2 + a_3) \leq (a'_s + a_e)/2$ within planes $G-G'$ and $H-H'$